

SIEMENS

Transmittal

	Date:	Siemens Project #
	Job Name	
	Your Order No.	

WE ARE SENDING YOU:

HEREWITH

UNDER SEPARATE COVER THE FOLLOWING ITEMS:

SUBMITTALS FOR REVIEW/APPROVAL

APPROVED SUBMITTALS

SUBMITTALS FOR YOUR USE

MARKED PLANS & SPECIFICATIONS

CERTIFIED PAYROLL

ENGINEERING COMMENTS

ORIGINAL DRAWINGS

OWNERS MANUALS

CHANGE ORDER(S)

AS-BUILT DRAWINGS

THESE ARE SUBMITTED:

FOR APPROVAL

FOR CORRECTION

FOR COMMENTS

FOR YOUR USE

PLEASE RETURN
OUR USE

APPROVED COPY(S) FOR

DESCRIPTION

IN ORDER TO PREPARE THE SUBMITTAL, WE NEED THE FOLLOWING INFORMATION AS CHECKED BELOW:

ARCHITECTURAL PLANS

MECHANICAL PLANS

ELECTRICAL PLANS

MECHANICAL SPECIFICATIONS

ELECTRICAL SPECIFICATIONS

BOILER WIRING

ELECTRICAL HEATING COIL WIRING

CHILLER WIRING

TERMINAL UNIT CUT SHEETS

HUMIDIFIER CUT SHEETS

DX COIL WIRING

COMPLETE SET(S) OF PLANS & SPECS.

PLEASE BE ADVISED THAT WE MUST HAVE THIS INFORMATION BEFORE WORK CAN BEGIN ON YOUR SUBMITTAL

REMARKS

PLEASE ADDRESS YOUR REMARKS TO: Siemens Industry, Inc. 104 Sebethe Drive Cromwell, CT 06416	ATTENTION:
	TELEPHONE:

SIEMENS

Siemens Industry, Inc.

Building Technologies Div.

104 Sebethe Drive

Cromwell, CT 06416

Phone: 860-635-4113

Owners Manuals For:

**Quinnipiac University Catholic
Center**

275 Mt Carmel Ave

Hamden, CT 06518

SIEMENS



PXC Modular Series Owner's Manual

125-3582
April 18, 2013

Building Technologies

Copyright Notice

Notice

Document information is subject to change without notice by Siemens Industry, Inc. Companies, names, and various data used in examples are fictitious unless otherwise noted. No part of this document may be reproduced or transmitted in any form or by any means, electronic or mechanical, for any purpose, without the express written permission of Siemens Industry, Inc.

Warning

This equipment generates, uses, and can radiate radio frequency energy. If equipment is not installed and used in accordance with the instructions manual, it may cause interference to radio communications. Equipment has been tested and found to comply within the limits for a Class B digital device pursuant to Part 15 of the FCC rules. These limits are designed to provide reasonable protection against such interference when operated in a commercial environment. Operation of this equipment in a residential area is likely to cause interference. Residential area equipment users are required to take whatever measures necessary to correct the interference at their own expense.

Service Statement

Control devices are combined to make a system. Each control device is mechanical in nature and all mechanical components must be regularly serviced to optimize their operation. Siemens Industry, Inc. branch offices and authorized distributors offer Technical Support Programs that will ensure continuous, trouble-free system performance.

For further information, contact your nearest Siemens Industry, Inc. representative.

Copyright 2013 by Siemens Industry, Inc.

FCC Regulations

The manual for an intentional or unintentional radiator shall caution the user that changes or modifications not expressly approved by the party responsible could void the user's authority to operate the equipment.

For a Class B digital device or peripheral, the instructions furnished the user shall include the following or similar statement, placed in a prominent location in the text of the manual:

NOTE: This equipment has been tested and found to comply with the limits for a Class B digital device, pursuant to part 15 of the FCC Rules. These limits are designed to provide reasonable protection against harmful interference in a residential installation. This equipment generates, uses and can radiate radio frequency energy and, if not installed and used in accordance with the instructions, may cause harmful interference to radio communications. However, there is no guarantee that interference will not occur in a particular installation. If this equipment does cause harmful interference to radio or television reception, which can be determined by turning the equipment off and on, the user is encouraged to try to correct the interference by one or more of the following measures:

- *Reorient or relocate the receiving antenna.*

-
- *Increase the separation between the equipment and receiver.*
 - *Connect the equipment into an outlet on a circuit different from that to which the receiver is connected.*
 - *Consult the dealer or an experienced radio/TV technician for help.*

To the Reader

Your feedback is important to us. If you have comments about this manual, please submit them to: mailto:Sbt_technical.editor.us.sbt@siemens.com

Credits

APOGEE, APOGEE GO, InfoCenter Administrator, InfoCenter Report Manager, InfoCenter Server, InfoCenter Suite, and Insight are registered trademarks of Siemens Industry, Inc.

Other product or company names mentioned herein may be the trademarks of their respective owners.

Printed in USA

Table of Contents

	How to Use This Manual	8
1	Chapter 1—Introduction	11
1.1	Modular Product Overview	11
1.1.1	Ordering Information	11
1.2	Compatibility with the APOGEE Automation System	13
1.2.1	BACnet Protocol Compatibility	13
1.2.2	TCP/IP Protocol Compatibility	14
1.3	Principles of Field Panel Operation	15
1.3.1	Gathering and Processing Field Inputs	15
1.3.2	Executing Control Programs	16
1.3.3	System Program	16
	License Manager	17
1.4	APOGEE Automation Networking	18
1.4.1	Management Level Network	18
1.4.2	Automation Level Network	18
1.4.3	Field Level Network	25
2	Chapter 2—Hardware Features.....	26
	PXC Modular Product Diagram	26
	Expansion Module Product Diagram	28
2.1	Memory	28
2.1.1	Flash Read-Only Memory (Flash ROM)	28
2.1.2	Random Access Memory (RAM)	30
2.2	Communication Connections	30
2.2.1	HMI and Tool Ports	31
2.2.2	10B/100B Ethernet Port	32
2.2.3	RS-485 Port	32
2.2.4	Expansion Module Overview	33
2.2.5	TX-I/O Island Bus	34
	Modular Series Smoke Control Application Requirements	34
	Example ALN Configuration for Smoke Control Applications	35
	PXM10S/T Product Overview and Description	36
	Product Features	37
	Requirements	38
	Application Menus	38
	Operator Display Layout	39
	Operator Display Menu Tree	41
	Main Menu Structure	41
	Login and Logoff	42
	Viewing, Commanding, and Releasing Points	48
	Configuring Point Monitor	52

	Configuring Settings.....	55
2.3	TX-I/O Product Range Overview.....	58
2.3.1	TX-I/O Module Overview.....	58
	TX-I/O Power Supply and Bus Modules.....	62
2.4	PX Series Enclosures and Service Boxes.....	65
2.4.1	PX Series Service Box Features.....	65
2.4.2	Product Numbers.....	67
2.4.3	PX Series Enclosure Specifications.....	68
2.4.4	PX Series Service Box Specifications.....	69
2.4.5	PX Series Enclosure Placement.....	69
	Chapter 3—Applications.....	72
	Operator Interface.....	72
	Field Panel GO.....	72
	Field Panel Web Server.....	73
	Powers Process Control Language (PPCL) Control Program and Point Database.....	74
	Control Programs.....	74
	Point Database.....	75
	Applications.....	75
	Adaptive Control.....	75
	Alarm Management.....	76
	Daylight Saving Time.....	76
	Equipment Scheduling.....	76
	Loop/Loop Tuning.....	76
	Start-Stop Time Optimization (SSTO).....	76
	Time and Calendar.....	77
	Trend Data Collection.....	77
	User Access and Privileges.....	77
	Customized Applications.....	78
	SNMP.....	78
3	Chapter 4—Troubleshooting.....	79
3.1	Service Information.....	79
3.1.1	Electrostatic Discharge.....	80
3.1.2	Error Status Messages.....	80
3.1.3	Ordering Replacement Parts.....	80
3.1.4	Replacing the Batteries.....	80
3.1.5	Reinstalling the Mounting Tabs.....	81
3.2	Troubleshooting Modular Field Panels.....	82
3.2.1	BATT LOW LED.....	82
3.2.2	RUN LED.....	83
3.2.3	TX and RX LEDs.....	83
3.2.4	Communication.....	83
3.2.5	Display.....	83
3.2.6	Errors.....	84

Troubleshooting the TX-I/O Island Bus	84
Glossary	86
Index	90

How to Use This Manual

About This Manual

This manual is written for the owner and user of the PXC Modular Series. It is designed to help you become familiar with the PXC Modular and its applications.

This section covers manual organization, document conventions and symbols used in the manual, how to access help, related publications, and any other information that will help you use this manual.

Document Organization

This manual contains the following chapters:

- *Chapter 1—Introduction*, describes each section in this manual and presents an overview of PXC Modular operation.
- *Chapter 2—Hardware Features*, describes the PXC Modular hardware components and their functions.
- *Chapter 3—Applications*, describes the operating system and applications available with the PXC Modular.
- *Chapter 4—Troubleshooting*, describes basic corrective measures you should take if you encounter a problem when using a PXC Modular.



NOTE:

The troubleshooting section is not meant to be a full diagnostic guide, but is designed to help you address basic troubleshooting issues. If you encounter a problem not covered in this section or require further assistance, consult your Siemens Industry representative.

- A *Glossary* describes the terms and acronyms used in this manual.
- An *Index* is provided to assist you in finding information presented in this manual.

Prerequisites

In addition to reading this owner's manual, you should also become familiar with the following technical documentation. Each document has been written to help you get the most out of your PXC Modular Series hardware.

These manuals, along with information about other Siemens Industry products, technical training classes, and services can be obtained from your local Siemens Industry representative.

- *Powers Process Control Language (PPCL) User's Manual* (125-1896). This manual describes Powers Process Control Language (PPCL), the language used to write the control programs for the PXC Modular.
- *APOGEE P2 ALN Field Panel User's Manual* (125-3019) or *APOGEE BACnet ALN Field Panel User's Manual* (125-3020). This manual describes the operator interface program used to communicate with APOGEE field panels. It contains information on defining the PXC Modular database, including slopes and intercepts.

For Smoke Control Applications

Smoke Control Systems Application and Engineering Manual (125-1806). This manual is a comprehensive reference on smoke control applications for APOGEE equipment. It contains all of the various agency requirements and recommended practices of organizations that are widely-recognized in composing standards and testing equipment involved in life safety applications.

When Using Insight Software

Insight 3.x Documentation. To view Insight 3.x documentation, see the Insight Online Documentation window, which you can access from the Insight Main Menu or the Insight program group.



Document Conventions

The following table lists conventions to help you use this manual in a quick and efficient manner.

Convention	Examples
Numbered Lists (1, 2, 3...) indicate a procedure with sequential steps.	<ol style="list-style-type: none"> 1. Turn OFF power to the field panel. 2. Turn ON power to the field panel. 3. Contact the local Siemens Industry representative.
<p>Conditions that must be completed or met before beginning a task are designated with a ▷.</p> <p>Intermediate results (what will happen following the execution of a step), are designated with a ⇨.</p> <p>Results, which inform the user that a task was completed successfully, are designated with a ⇩.</p>	<p>▷Composer software is properly installed.</p> <p>▷A Valid license is available.</p> <ol style="list-style-type: none"> 1. Select Start > Programs > Siemens > GMS > Composer. <p>⇨The Project Management window displays.</p> <ol style="list-style-type: none"> 2. Open an existing project or create a new one. <p>⇩The project window displays.</p>
Actions that should be performed are specified in boldface font.	<p>Type F for Field panels.</p> <p>Click OK to save changes and close the dialog box.</p>
Error and system messages are displayed in Courier New font.	The message <code>Report Definition successfully renamed</code> displays in the status bar.
New terms appearing for the first time are italicized.	The field panel continuously executes a user-defined set of instructions called the <i>control program</i> .
	This symbol signifies Notes. Notes provide additional information or helpful hints.
Cross references to other information are indicated with an arrow and the page number, enclosed in brackets: [→92]	For more information on creating flowcharts, see Flowcharts [→92].

Safety Symbols

The following table lists the safety symbols used in this manual to draw attention to important information.

Symbol	Meaning	Description
NOTICE	CAUTION	Equipment damage may occur if a procedure or instruction is not followed as specified. (For online documentation, the NOTICE displays in white with a blue background.)
	CAUTION	Minor or moderate injury may occur if you do not perform a procedure as specified.
	WARNING	Personal injury or property damage may occur if you do not perform a procedure as specified.
	DANGER	Electric shock, death, or severe property damage may occur if you do not perform a procedure as specified.

Getting Help

For more information about APOGEE products, contact your local Siemens Industry representative.

1 Chapter 1—Introduction

Chapter 1 provides an introduction to the PXC Modular Series and how it is integrated with the APOGEE Automation System. The following topics are discussed:

- PXC Modular Series Product Overview
- Compatibility with the APOGEE Automation System
 - BACnet Protocol Compatibility
 - TCP/IP Protocol Compatibility
- Principles of PXC Modular Operation
 - Gathering and Processing Field Inputs
 - Executing Control Programs
 - System Program
- APOGEE Automation Networking
 - Management Level Network
 - Automation Level Network
 - Field Level Network

1.1 Modular Product Overview

The PXC Modular is an integral part of the APOGEE Automation System. It is a high performance, modular Direct Digital Control (DDC) supervisory field panel.

The field panel operates stand-alone or networked to perform complex control, monitoring, and energy management functions without relying on a higher level processor.

- Up to 100 PXC Modular field panels communicate on a peer-to-peer network.
- With the addition of TX-I/O modules and a TX-I/O Power Supply on a self-forming bus, the PXC Modular can directly control up to 500 points.



See the *APOGEE Wiring Guidelines for Field Panels and Equipment Controllers* (125-3002) for information on setting up this configuration.

- With the addition of an Expansion Module, the PXC Modular also provides central monitoring and control for distributed wireless or wired Field Level Network (FLN) devices.

1.1.1 Ordering Information

Product Number	Description
PXC00-E96.A	PXC Modular, BACnet/IP or MS/TP ALN, P1 or MS/TP FLN. PXX-485.3 is also required as the connection to the FLN devices.
PXC00-PE96.A	PXC Modular, Ethernet/IP or RS-485 ALN, P1 FLN. PXX-485.3 is also required as the connection to the FLN devices.
PXC100-E96.A	PXC Modular, BACnet/IP or MS/TP ALN, P1 or MS/TP FLN, self-forming TX-I/O Island Bus. PXX-485.3 is also required as the connection to the FLN devices.

Product Number	Description
PXC100-PE96.A	PXC Modular, Ethernet/IP or RS-485 ALN, P1 FLN, self-forming TX-I/O Island Bus. PXX-485.3 is also required as the connection to the FLN devices.
PXX-485.3	Provides FLN support for the PXC Modular. Includes three RS-485 P1 FLN connections or one MS/TP FLN connection; maximum of 96 devices supported.

Optional Licenses

Product Number	Description
PXF-TXIO.A	License to enable the Island Bus on PXC00-E96.A and PXC00-PE96.A.
LSM-FPGO	License to enable Field Panel GO
LSM-SNMP	License to enable SNMP Agent on Siemens Modular or Compact hardware with BACnet Firmware Revision 3.2.3
LSM-VAEM	License to enable Virtual AEM support when the P2 ALN is connected to RS-485
LSM-FPWEB	License to enable BACnet Web Server (PXC-36) or Web Services (PXC-16/24)

TX-I/O I/O Modules

Product Number	Description
TXM1.8D	TX-I/O Module, 8 DI points
TXM1.16D	TX-I/O Module, 16 DI points
TXM1.8U	TX-I/O Module, 8 Universal points
TXM1.8U-ML	TX-I/O Module, 8 Universal points with LOID
TXM1.8X	TX-I/O Module, 8 Super Universal points
TXM1.8X-ML	TX-I/O Module, 8 Super Universal points with LOID
TXM1.6R	TX-I/O Module, 6 DO with Relay points
TXM1.6R-M	TX-I/O Module, 6 DO with Relay points with manual override

TX-I/O Power Supply and Bus Modules

Product Number	Description
TXS1.12F4	TX-I/O Power Supply, 1.2A, 4A Fuse
TXS1.EF4	TX-I/O Bus Connection Module, 4A Fuse

TXA1.IBE	TXIO Island Bus Expansion module with RS-485 connection.
----------	--

TXB1.P1	TX-I/O Bus Interface Module, P1 (10-module)
TXB1.P1-4	TX-I/O Bus Interface Module, P1 (4-module)

Accessories

Product Number	Description
TXA1.K12	One set of address keys, numbers 1 - 12.
TXA1.K24	One set of address keys, numbers 1 - 24.
TXA1.K-48	One set of address keys, numbers 25 - 48.

Product Number	Description
TXA1.K-72	One set of address keys, numbers 49 - 72.
TXA1.LLT-P100	Labels for TX-I/O, 100 sheets/pack, letter format.
TXA1.LH	Replacement label holders.

1.2 Compatibility with the APOGEE Automation System

The PXC Modular Series is fully compatible with, and will communicate with, all the APOGEE or pre-APOGEE products in your facility.

For more information on compatibility of products, contact your Siemens Industry representative.



⚠ CAUTION

When working on a network with multiple firmware revisions, always connect to the operator interface at the field panel with the newest firmware revision.

Otherwise, you will not be able to view features in newer firmware revisions, or you may coldstart the field panel.

1.2.1 BACnet Protocol Compatibility

APOGEE BACnet is compatible with the BACnet/IP protocol.



⚠ CAUTION

When sharing data values from APOGEE P2 (proprietary) field panels to BACnet devices, the Cross-Trunk Service does not support requests originating from BACnet devices to access points (objects) that reside in APOGEE P2 field panels.

If you plan to share data values from APOGEE P2 field panels with BACnet devices (field panels), you must do one of the following:

- Install and enable the Insight BACnet Server Option.
- Use PPCL in the APOGEE P2 field panels to command values in the BACnet devices through the Insight Cross-Trunk service.

APOGEE P2 and BACnet Product Features Order of Implementation

The APOGEE field panel firmware supports the BACnet protocol as follows:

- If both the BACnet and APOGEE protocols have a function, the BACnet function is implemented.
- If APOGEE provides a function that the BACnet protocol does not support, the APOGEE function is retained.

This approach to BACnet implementation retains the APOGEE feature set while providing compatibility with standard BACnet/IP protocol.

1.2.2 TCP/IP Protocol Compatibility

PXC Modular Series controllers with BACnet/IP or Ethernet TCP/IP (P2) ALN provide the following:

- 100% compatibility with the TCP/IP protocol suite.
- Support of Dynamic Host Configuration Protocol (DHCP) and Domain Name Servers (DNS).
- Support and auto detection of 10Base-T and 100Base-TX Ethernet.

1.2.2.1 Required IP Addresses

APOGEE BACnet/IP or Ethernet TCP/IP (P2) ALN uses:

- One IP address per device (field panel or Insight workstation).
- One additional shared IP address per ALN for the multicast group (when using multicast optimization).

1.2.2.2 Device Registration

Devices register with the DHCP server and Domain Name Server, if either is present.

1.2.2.3 Address Assignment

IP addresses are dynamically assigned by the DHCP server.

If an address changes or is not recognized, the field panel firmware lets you release the dynamically assigned IP address and then reconnect the field panel to the DHCP server, accepting a new IP address assignment in the process.

If there is no DHCP server at the site, you must manually assign static IP addresses as part of the startup system configuration.

Physical Addressing

Each device on the BACnet/IP or Ethernet TCP/IP (P2) ALN has a hard-wired MAC address, which is printed on the product label.

Port Numbers

The default TCP/IP port number for APOGEE BACnet/IP or Ethernet TCP/IP (P2) ALN communications is **5033**. You can change the TCP/IP port number if necessary.

**NOTE:**

All devices on the network must use the same TCP/IP port number.

The default TCP/IP port number for Virtual AEM communications is **3001**.

You must specify a UDP port number when using multicast optimization. The default UDP port number is **8**.

Network Bandwidth

BACnet/IP or Ethernet TCP/IP (P2) ALN does not add significantly to your network overhead. Burst conditions for this product occur during:

- Database downloading after coldstart.
- Database uploading.
- Trend data uploading.
- Burst of alarms or COVs.

Data Exchange

BACnet/IP or Ethernet TCP/IP (P2) ALN sends and receives APOGEE data in TCP/IP packets.

BACnet/IP or Ethernet TCP/IP (P2) ALN synchronizes global data between all devices. Each device runs a global data replication engine that communicates with peer devices to:

- Exchange new and changed global data.
- Resolve conflicts when data does not match.

Device Naming Conventions

Field panel DNS node names are limited to 30 characters and cannot contain spaces.

Network Security

BACnet/IP or Ethernet TCP/IP (P2) ALN uses your intranet security within the firewall and a username/password combination to restrict access outside the firewall. You can use VLAN to improve internal security.

1.3 Principles of Field Panel Operation

The PXC Modular Series gathers information about the environment of your facility, as well as the equipment it monitors and controls. The PXC Modular receives updated information, stores information, executes control programs, handles operator commands and requests, and makes control management decisions. At the same time, the PXC Modular also translates decisions into actions and allows the operator to observe those actions. The operator can also override and modify the decisions made by the PXC Modular.

1.3.1 Gathering and Processing Field Inputs

The PXC Modular samples the information at all field inputs, or points, approximately once each second, and stores numerical representations of the sampled values.

Under certain conditions, some points require additional handling. The PXC Modular initiates required actions after these points are checked against previously-entered configuration data.

Example

A log entry might be required in a point history file every 20 samples, or notification of an alarm condition could be sent to the operator as a point crossed the alarm threshold.

1.3.2 Executing Control Programs

The PXC Modular continuously executes a user-defined set of instructions called the control program. This program uses the most recent point values and the most recent clock time. The control program does the following:

- Evaluates control strategies.
- Uses an internal calendar and time clock for time-based functions.
- Updates point values and commands field points according to the program results.
- Sends messages or reports to proper terminal locations as needed.

Example

During occupied hours (7:00 A.M. through 5:00 P.M.) a fan:

- Turns ON if the room temperature rises above 80°F (27°C).
- Turns OFF when the temperature drops below 73°F (23°C).

Between 5:00 P.M. and 7:00 A.M. the fan turns OFF regardless of the room temperature.

If the temperature rises to 85°F (29°C) at any time, the PXC Modular sends an alarm message to an alarm printer.

These specifications can be met by:

1. Connecting a room temperature sensor/transmitter and fan starter output to the PXC Modular.
2. Defining the room temperature sensor with a high alarm limit of 85°F (29°C) and the fan points in the PXC Modular database.
3. Writing a short control program that defines your control strategy.
4. Enabling the execution for that portion of the control program.

To perform this control strategy, the PXC Modular:

- Continuously executes the control program.
- Samples a current or voltage signal representing the room temperature and updates the value associated with that temperature in its memory.
 - If the temperature rises to 85°F (29°C), then the PXC Modular sends an alarm message to the printer.
- Checks the current time once per second.
 - Between 5:00 P.M. and 7:00 A.M., the fan remains OFF.
 - Between 7:00 A.M. and 5:00 P.M., the control program checks the current value of the temperature and sends the appropriate ON or OFF command to the fan starter.

If the ON command is issued, the PXC Modular updates the value of the starter point in its memory to reflect the current state of the fan.

1.3.3 System Program

The PXC Modular contains a non-volatile system program called firmware, which can be upgraded in the field. The firmware is stored in Flash ROM memory, which keeps it

virtually immune to all forms of power fluctuations or failure, including battery failure. For more information on Flash ROM memory, see Memory [→ 28].

General functionality of the firmware includes:

- Executing control programs.
- Communicating between other field panels and the Insight workstation.
- Monitoring points.
- Managing point-related information.
- Keeping track of real time (both clock and calendar time).
- Executing self-test and error detection in the PXC Modular.

License Manager

License Manager adds applications or functionality to a field panel without the need to replace the hardware or perform a firmware flash. Field panels with Firmware Revision 2.8.2/3.0.1 or later support the License Management attribute.

Contact your Siemens Industry representative for more information on applications and functionality that can be activated through License Manager.

License Manager Definitions

- A *feature* is an application or additional functionality that can be added to a field panel without the need to replace the hardware. Some features require a firmware flash.
- A *license* is the code provided by Siemens Industry to unlock a feature.
- The *ID_STRING* is a unique identifier that distinguishes an individual piece of hardware. It is composed of the panel's part number, revision, year and week of manufacture, and serial number. Therefore, a license for one field panel will not work on another field panel.

How does License Manager Work?

Field panels can either be ordered with licensed features and functionality pre-loaded, for example, FLN or TX-I/O island bus support, or upgraded to add special features, for example, integration drivers, Field Panel GO, and Virtual AEM.



NOTE:

The installation of some features and licenses require that the field panel be coldstarted, while others do not. For example, Field Panel GO requires the creation of Web server folders and therefore requires that the field panel be coldstarted. However, TX-I/O module installation does not.

Any or all of the licensed features can be activated at any time using licenses acquired from Siemens.

When the field panel is powered, the firmware reviews the inventory of installed features, comparing that list to the License Vault, where all installed licenses are stored. Every feature with a corresponding license is initiated and run. Because licenses are loaded into non-volatile memory, powering down the field panel will not erase them.

1.4 APOGEE Automation Networking

The following levels of networking provide varying levels of system integration in the APOGEE Automation System.

- Management Level Network (MLN)
- Automation Level Network (ALN)
- Remote Automation Level Network
- Field Level Network (FLN)

These systems also use a number of network protocols that add functionality or provide support for third-party devices.

1.4.1 Management Level Network

The Management Level Network (MLN) is the communications connection between individual Insight workstations. It allows multiple Insight users to access the entire APOGEE Automation System.

- An MLN is a TCP/IP Server-client network, and usually resides on the corporate LAN.
- APOGEE Automation Systems without an Insight workstation do not have a Management Level Network.

1.4.2 Automation Level Network

The APOGEE Automation Level Network (ALN) provides field panel-to-field panel and Insight workstation-to-field panel communication. The ALN types are:

- P2 RS-485 ALN
- Ethernet TCP/IP ALN
- Remote ALN (Auto-dial and AEM)
- BACnet/IP ALN
- BACnet Master-Slave/Token Passing (MS/TP) ALN

1.4.2.1 Simultaneous ALN Access

More than one operator or field panel can access the network at one time. For example, as one operator accesses the system, another operator can access the system at another terminal (or from a remote site using a modem). This ensures that field panels can send alarm information to the alarm printer even as an operator accesses other information.

1.4.2.2 How Information Moves Through the Network

When an operator issues a command over the ALN network through a field panel, that field panel validates the command, determines where to send it, and then passes the command to the destination over the network.

Example

In the figure *Commanding Over an Automation Level Network*, the operator at the Insight workstation, located in the lower level of the building, issues a command to control the main air-handling unit (AHU) of the building. This command is sent by the communication network to the field panel located on the top floor.

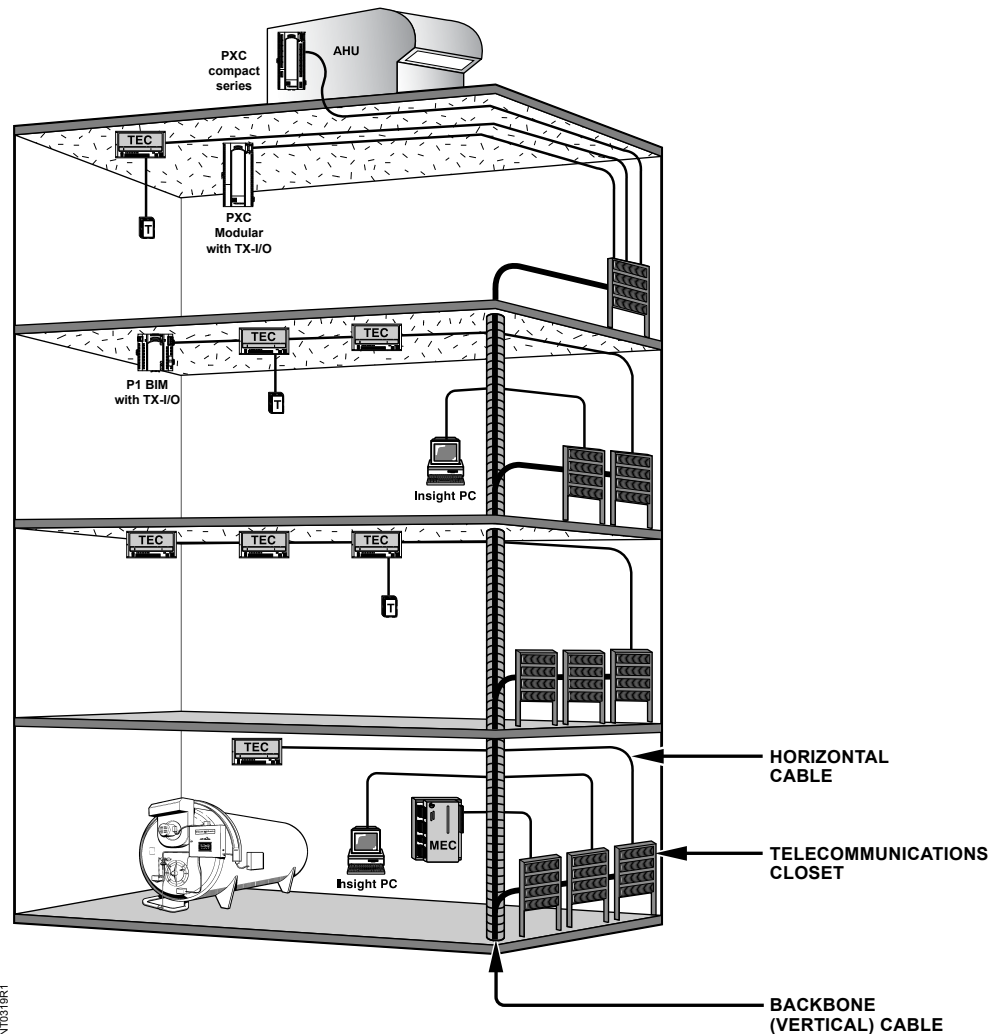

Figure 1: Figure. *Commanding Over an Automation Level Network*.

1.4.2.3 RS-485 P2 Automation Level Network

The RS-485 ALN is a proprietary token-passing network that communicates over RS-485 cabling. It is Protocol 3 (P3) at and above 38,400 bps, and Protocol 2 (P2) below 38,400 bps.

- An Insight workstation is optional with this ALN.
- Up to 100 field panels (99 with an Insight workstation) can be connected and can communicate by means of an RS-485 peer-to-peer network.
- Information can be sent and retrieved across the RS-485 ALN from any connected field panel.

Media

The RS-485 ALN can communicate over one or more of the following:

- Physical wire (RS-485 cabling)
- Dedicated telephone lines
- Leased-line modems
- Line drivers
- Trunk Isolator Extenders (TIE)
- Fiber Optic Interfaces

The trunk system provides connections within buildings or between buildings for multiple field panels and operator workstations.

The following figure shows a possible implementation of an RS-485 ALN network.

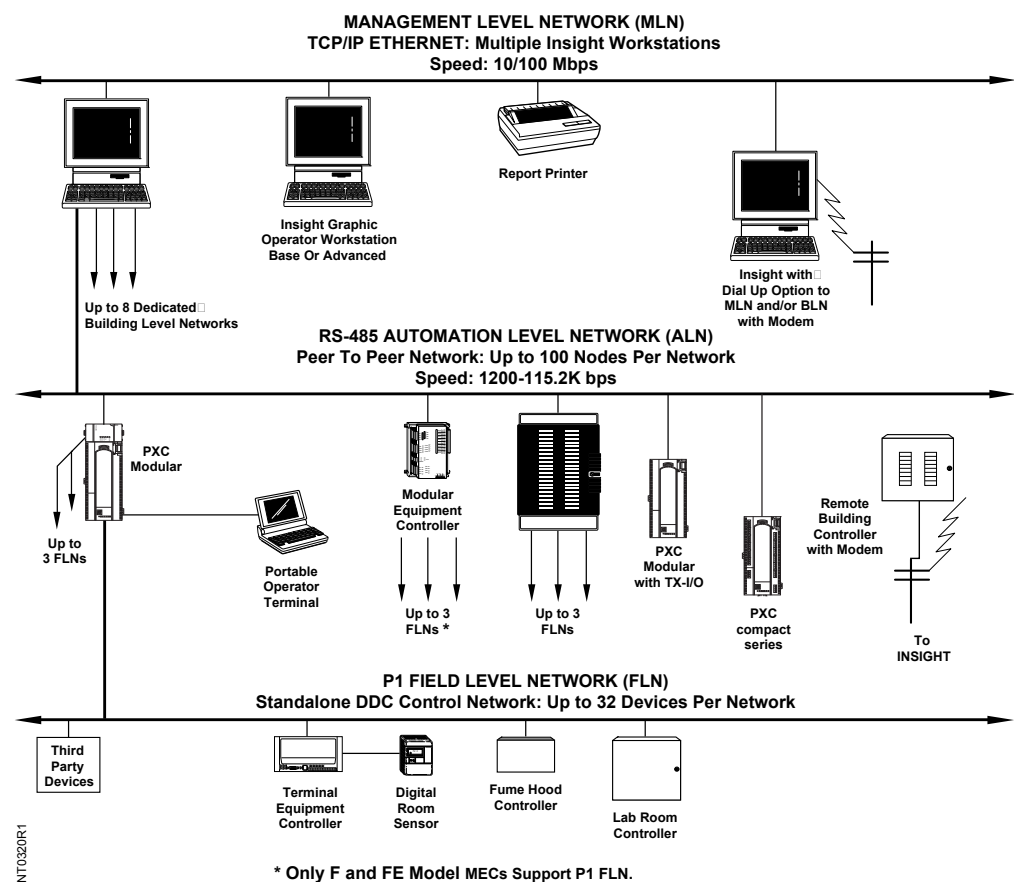

Figure 2: MLN, RS-485 ALN, and P1 FLN network example.

1.4.2.4 Ethernet TCP/IP Automation Level Network

The Ethernet Automation Level Network (EALN) uses TCP/IP-based communication over a customer's Ethernet cabling and IP network to reduce overall system and maintenance costs. Otherwise, system operation is identical to RS-485 ALN installations.

- An Insight workstation is optional with this ALN.

- When an Insight workstation is used, multiple Insight workstations can be defined on the MLN.
- A maximum of 1000 Ethernet field panels can be defined for each Insight workstation on the MLN.
- Each Insight workstation can host up to 64 EALNs.
- The Insight workstation counts as a node on every EALN to which it is connected.

Information can be sent and retrieved across the EALN from any Ethernet capable field panel. The following figure shows a possible implementation of EALN over a corporate IP network. In this example, the MBCs contain Power Open Processors with Ethernet ALN.

MANAGEMENT LEVEL NETWORK (MLN)
A Maximum of 1,000 Ethernet Field Panels can be Defined for Each Insight Workstation on the MLN.

INSIGHT Workstations
(Windows® 2000 or Windows® XP)

NOTE: The Insight Workstation Counts as a Node on Every EALN to Which it is Connected.

Multiple Insight Workstations can be Defined, Each Hosting Up to 64 EALNs

ETHERNET AUTOMATION LEVEL NETWORK (EALN)
100 Nodes Maximum per EALN (99 with Insight Workstation)

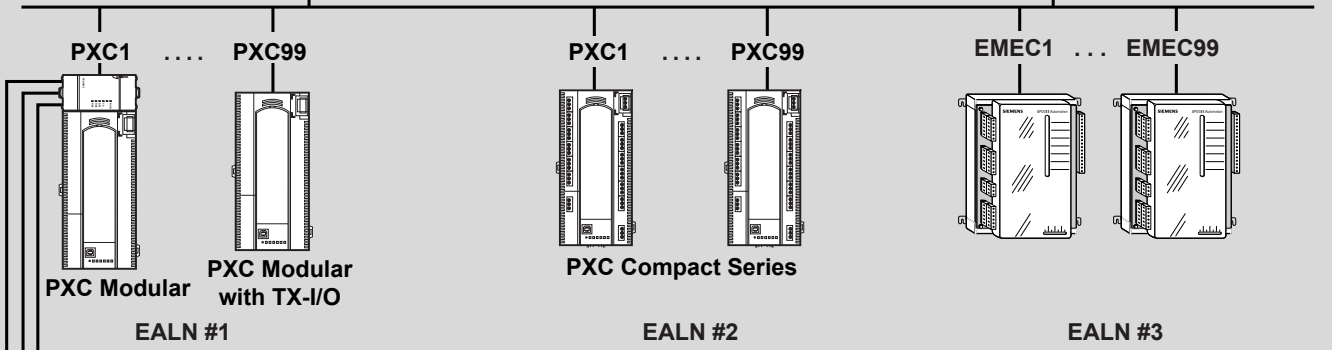

P1 FIELD LEVEL NETWORK (FLN)
Each Field Panel with P1 FLN support has 3 FLN ports.
Each P1 FLN port controls up to 32 devices.

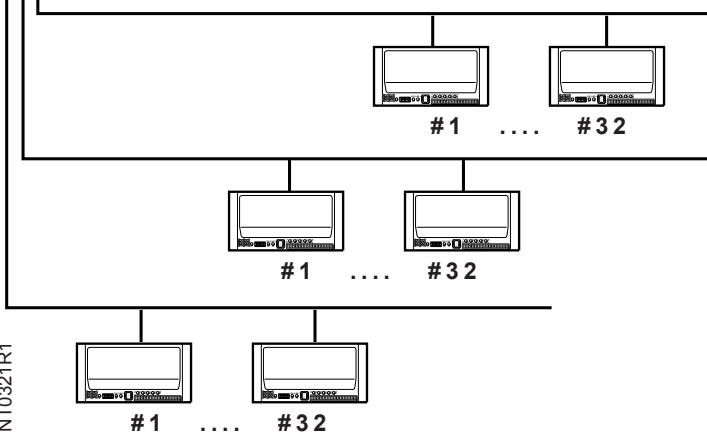

NT0321R1

Figure 3: MLN, Ethernet ALN, and P1 FLN network example.

1.4.2.5 Remote Automation Level Network (Single Field Panel Remote Sites)

One PXC Modular can act as a stand-alone field panel. A stand-alone field panel is generally used in remote sites where only one field panel is needed to control the equipment for that site. Communications with the remote site are achieved by using modems or the Virtual APOGEE Ethernet Microserver (AEM).

The remote site PXC Modular can initiate a telephone call to a device such as a personal computer running Insight software, a dumb terminal, or a printer. Once the remote site connects to the device, an alarm or other user-defined event is issued. When the remote site no longer requires the connection to the device, the remote site disconnects. The remote site can also receive telephone calls from a device running Insight software to allow for centralized access of a local network's database.

The Virtual APOGEE Ethernet Microserver (AEM) allows an Automation Level Network (ALN) to be connected directly to an Ethernet network at all times (versus a modem, which connects when necessary). The ALN can consist of a single remote field panel or a maximum of 32 field panels.

For local access, operators can communicate with the remote site by physically connecting to the field panel via an operator's terminal. When an operator issues a command, the field panel validates the command and sends it to the appropriate device.

For more information about remote site field panels, contact your Siemens Industry representative.

1.4.2.6 BACnet/IP Automation Level Network

BACnet field panels communicate over a customer's Ethernet cabling and IP network using the ASHRAE Building Automation and Control Networking (BACnet) protocol.

- One Insight workstation can administer up to 64 Ethernet-based BACnet/IP ALNs.
- Up to 100 BACnet/IP or Ethernet TCP/IP (P2) field panels can reside on a BACnet/IP network (1000 maximum per Insight workstation).
- Because they use different networking protocols, APOGEE P2 Ethernet TCP/IP and BACnet/IP field panels cannot communicate directly with each other, even on the same physical network.

The following figure shows a possible implementation of APOGEE P2 Ethernet ALN and BACnet/IP ALN over a corporate IP network.

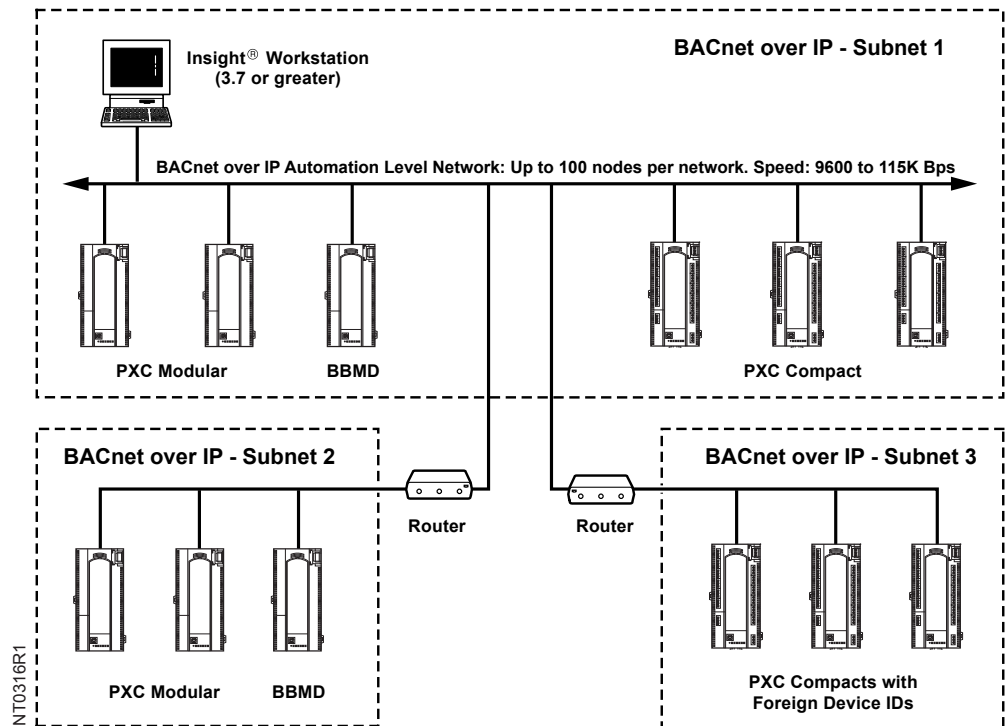

1.4.2.7 BACnet MS/TP Automation Level Network

BACnet field panels communicate over a customer's Ethernet cabling and IP network using the ASHRAE Building Automation and Control Networking (BACnet) MS/TP protocol.

- One Insight workstation can administer up to 64 Ethernet based MS/TP ALNs.
- Up to 10 BACnet MS/TP ALN field panels can reside on an MS/TP network segment (1000 maximum per Insight workstation). Network segments must be physically separated.
- BACnet devices (field panels or Insight workstations) can be set up as one of the following:
 - A standard BACnet MS/TP device
 - A BACnet Broadcast Management Device (BBMD)
 - A foreign device

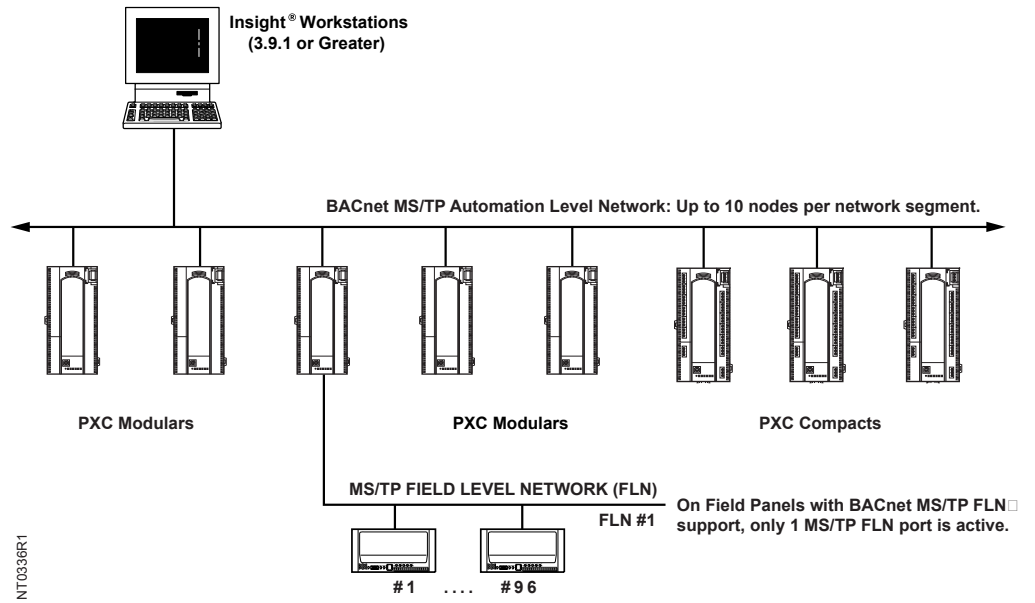

1.4.3 Field Level Network

The APOGEE Field Level Network (FLN) is a data communications network that passes information between an FLN device or devices and an Automation Level Network (ALN) device, usually within one building. FLNs consist of devices that communicate using RS-485 P1 or MS/TP.

- P1 devices can include Terminal Equipment Controllers (TEC), Fume Hood Controllers (FHC) and other vendor equipment, such as ABB Speed Drives, which contain Protocol 1.
- Selected models of APOGEE field panels can communicate with other vendor protocols on the FLN, such as McQuay, Lumisys, EST IRC-3, and Allen Bradley. Contact your Siemens Industry representative for information on devices that can communicate with other vendor protocols.

2 Chapter 2—Hardware Features



Chapter 2 describes the PXC Modular Series components and functions, as well as the enclosure used for the PXC field panel series. The following topics are discussed:

- Product Diagrams
- Backup Batteries
- Memory
- Communication Connections
- PXC Modular Series Specifications
- Modular Series Smoke Control Application Requirements
- TX-I/O Product Range
- PX Series Enclosures and Service Boxes

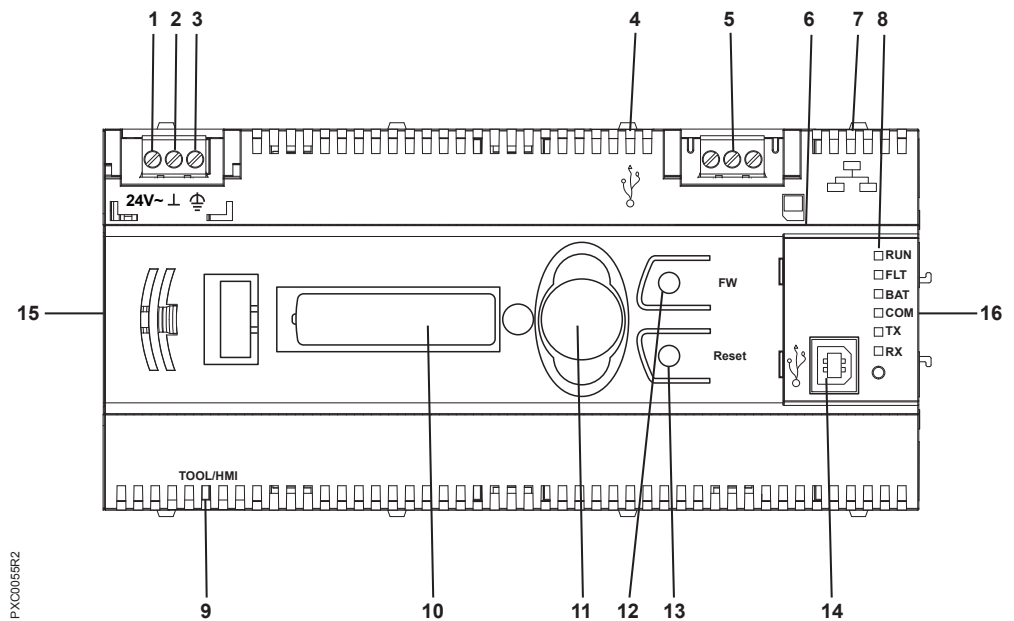
PXC Modular Product Diagram



Modular Series Features, Symbols, and Status LEDs.			
Label	LED, Symbol, or Feature	Status	Indication
1	24V~	-	Supply voltage, 24 Vac input.
2	⊥	-	System neutral.
3	⏏	-	Functional earth ground.
4	USB symbol	-	USB Host port. (Ancillary smoke control applications only.)
5	S - +	-	RS-485 P2 or BACnet MS/TP Automation Level Network (ALN) port.

Modular Series Features, Symbols, and Status LEDs.			
Label	LED, Symbol, or Feature	Status	Indication
6		-	Secure Digital (SD) memory card slot. (For future use.)
7		-	BACnet/IP or Ethernet TCP/IP (P2) Automation Level Network (ALN) port.
8	RUN (green)	ON	Normal operation. 24 Vac power is ON and the application firmware has booted.
		OFF	Error. - 24 Vac input is not present. - Power is ON, but the application firmware has not booted.
	FLT (red) (for future use)	-	-
	BAT (red)	ON	Error. Backup battery is low. Replace the battery.
		OFF	Normal operation.
	COM (yellow) (Ethernet only)	ON	Linked to Ethernet hub.
		OFF	No link to Ethernet hub.
		Flashing	Linked to Ethernet hub and communicating.
TX (yellow) and RX (yellow) (RS-485 only)	Flashing	Normal operation. Transmitting (TX) or receiving (RX) over the RS-485 ALN trunk.	
	OFF or Flashing	Error. No device, no connection, or bad connection.	
9	Tool/HMI	-	Human-Machine Interface port (RJ-45, service only).
10	AA alkaline battery	-	SDRAM backup battery. See BAT LED in this table for related indication.
11	Coin cell battery	-	Real Time Clock backup battery.
12	FW (for future use)	-	Firmware reset button.
13	Reset	-	Hardware reset button. Coldstarts the PXC Modular.
14		-	USB Device port. For non-smoke control applications only.
15	Expansion port	-	Connection for an RS-485 Expansion Module or future expansion devices.
16	TX-I/O bus connector (male)	-	Connection for a TX-I/O Power Supply or Bus Connection Module, which powers TX-I/O Modules.

Expansion Module Product Diagram

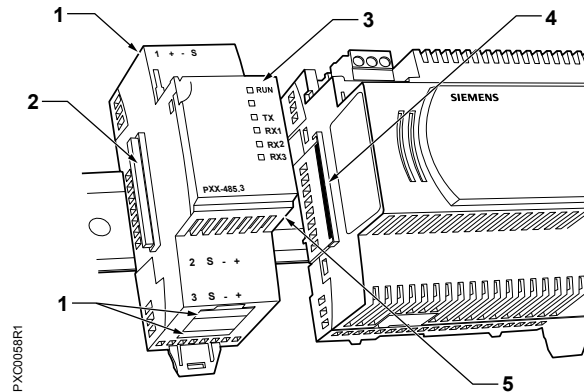

	LED, Symbol, or Feature	Status	Indication
1	S - +	--	RS-485 P1 or MS/TP Field Level Network (FLN) ports.
2	Expansion connector	--	Connection for future expansion devices.
3	RUN (green)	ON	Normal operation. 24 Vac power is ON and the module firmware has booted.
		OFF	Error. <ul style="list-style-type: none"> ● 24 Vac input is not present. ● Power is ON, but the module firmware has not booted.
	TX (yellow) and RX (yellow)	Flashing	Normal operation. Transmitting (TX) or receiving (RX) over the RS-485 ALN trunk.
		OFF or ON solid	Error. No device, no connection, or bad connection.
4	PXC Modular Expansion port	--	PXC Modular connection for an RS-485 Expansion Module or future expansion devices.
5	Expansion connector	--	Connection to the PXC Modular.

2.1 Memory

The APOGEE firmware (program), its point database, PPCL program, trend data, and other information reside in the field panel memory. Memory consists of two areas: Flash Read-Only Memory (Flash ROM) and Random Access Memory (RAM).

2.1.1 Flash Read-Only Memory (Flash ROM)

Flash Read-Only Memory (Flash ROM) is the non-volatile, permanent memory of the PXC Modular, which stores the operating system, the APOGEE firmware, and the language files. A limited amount of secondary storage is provided in Electrically Erasable Programmable Read-Only Memory (EEPROM) for the field panel address or name, communication speeds, and other set-up parameters. In the event of a power surge, a power loss, or failure of the battery backup, the Flash ROM and EEPROM contents stay intact.

PXC Modular Flash ROM size cannot be upgraded in the field.

2.1.1.1 Compressed ROM

The PXC Modular has a large amount of high performance RAM. To allow for future features and to provide high system performance, the APOGEE firmware is stored in ROM in a compressed state; it is de-compressed into RAM on system power-up. As a result, the entire onboard RAM is not available for the point database, the PPCL program, and trend data.

2.1.1.2 Auto-Restore and Database Backup to Flash

APOGEE Firmware Revision 2.8.4/3.1 and later supports Auto-Restore and Database Backup to Flash.

- Database Backup to Flash allows the user to manually save a copy of the database in flash memory of the controller.
- The field panel may also be configured to automatically restore the database from flash memory after a coldstart.
 - When auto-restore is enabled, a coldstart does not result in the same downtime as with earlier revisions of APOGEE Firmware. Because there is no waiting on a full download from the backup system, the database is restored from flash so quickly that there is little to no down time. However, the accumulated trend data is deleted from memory.
 - Database restoration from flash is disabled by default.
 - When P1 Mode is selected for the PXC Compact, database restoration from flash is automatically enabled and 128K of memory is reserved for ISB files.

For procedures on using Auto-Restore and Database Backup to Flash, see the *APOGEE P2 ALN Field Panel User's Manual* (125-3019) or *APOGEE BACnet ALN Field Panel User's Manual* (125-3020).

Auto Save

This feature allows the database to be backed up automatically whenever database is changed, instead of being an operator selected function. It does not provide any safeguard and or protection against power loss while the process is underway. However, this feature sends messages to HMI that the auto save operation is in progress or finished.

The feature may be turned on or off using a prompt similar to the existing Autorestore prompt. See the *APOGEE BACnet ALN Field Panel User's Manual* (125-3020) for more information.

File System Operations

File System Operations provide many features and works on three drives of a field panel.

The following is a list of supported features: :

- List Drives — list the drives on the field panel where **A:** is the RAM drive, **B:** is the USB drive if attached, **IFD:** is the internal Flash Drive.
- Set_drive — identifies the drive that you desire to perform other functions on.

- listDirectory — lists the Files and folders contained on the selected drive.
- Change_dir — changes the current directory to allow you to view the contents of subfolders on the drive.
- File_ops — opens up the file control menu which allows you to copy, rename, delete and move files in the panel. These functions work on the drive that was selected by the Set_drive function.
- File_ops/Copy_file — allows you to copy files within a drive or to another drive.
- File_ops/Rename_file — allows you to rename a file.
- File_ops/Move_file — allows you to move a file within a drive or to another drive.
- File_ops/Delete_file — allows you to delete a file.

USB Media Support

- Support for USB mass storage devices (Memory sticks or USB hard drives).
- Backup of database, storage for graphics, Web Server upgrades

2.1.2 Random Access Memory (RAM)

Synchronous Dynamic Random Access Memory (SDRAM) is the working memory of the PXC Modular. When the PXC Modular has booted and is operating normally, the APOGEE firmware, the PPCL control program, the point database, and trend data have been transferred from Flash ROM. Information stored in RAM, such as the point database or PPCL, may be viewed, modified, deleted, activated, or deactivated from an operator terminal by any high-level authorized user. In the event of a power loss, the contents of RAM are kept intact by a backup battery.

PXC Modular RAM size cannot be upgraded in the field.

The program length, number of database points, and number of trend entries is limited only by available memory.

2.2 Communication Connections

The PXC Modular Series operates on the Automation Level Network (ALN) or the Field Level Network (FLN).

- When connected to the ALN, the PXC Modular uses a logical point firmware database to communicate directly with PXC Compacts, MBCs, RBCs, MECs, SCUs, and other nodes on the network.
- When connected to the MS/TP FLN, the PXC Modular operates as a third-party BACnet device.

The PXC Modular provides the following communication connections:

- HMI and Tools
- Network
 - 10B/100B Ethernet port
 - RS-485 port
 - USB Host port
- PXC Modular Expansion Module
- TX-I/O Bus

The following connections and features are available when communicating on a BACnet/IP Automation Level Network:

- Ethernet port
- RS-485 Port
- USB Host port
- Web Server support: Web-based Graphical User Interface (GUI) compatible with BACnet® networks. Ideal for small or remote facilities to monitor and control the Building Automation System.

The following connections and features are available when communicating on an Ethernet TCP/IP Automation Level Network:

- Ethernet port
- USB Host port
- Field Panel GO, a Web-based graphical user interface for the APOGEE System. Field Panel GO is suited for sites with up to six field panels on the Ethernet ALN. (Additional license required.)

The PXC Modular hardware can be changed between RS-485 P2 and Ethernet ALN through the HMI. The factory default is Ethernet ALN.



NOTE:

Changing the ALN type coldstarts the field panel.



NOTE:

In Ethernet ALN mode, RS-485 P2 parameters are displayed and may be entered as a selection. However, when in RS-485 P2 ALN mode, Ethernet ALN parameters are not an available selection.

2.2.1 HMI and Tool Ports

- The HMI port provides a connection to a laptop computer for local operation and engineering.
- The USB Device port supports a generic serial interface for an HMI or Tool connection.

Human-Machine Interface (HMI)/Tool Port

The Human-Machine Interface (HMI)/Tool port provides RS-232 compliant communications through a quick-connect RJ-45 jack. The HMI port supports the following functionality:

- Connecting a machine interface device, such as an operator terminal or a text-based operator terminal, to the PXC Modular.
- Executing firmware flash upgrades.
- 1200 bps to 115.2 Kbps communication is supported.

**NOTE:**

The communication speed of the port must match the communication speed of the device connected to it.

USB Device Port

The USB Device port supports a generic serial interface for an HMI or Tool device. The USB Device port does not support firmware flash upgrades.

2.2.2 10B/100B Ethernet Port

The 10B/100B Ethernet port provides a path for commands and information transmitted between field panels inside a firewall. This port provides both full- and half-duplex 10Base-T or 100Base-TX compliant communications over a BACnet/IP or Ethernet TCP/IP (P2) Automation Level Network (ALN). The highest possible communication speed is automatically detected and selected.

2.2.3 RS-485 Port

The RS-485 port provides a path for commands and information transmitted between field panels. This port provides communications over a RS-485 P2 or BACnet MS/TP Automation Level Network (ALN). The communication speed is set during startup.

The RS-485 port provides half-duplex, asynchronous serial RS-485 communications over shielded twisted pair cable. The RS-485 connector is labeled + – ↓ to indicate the positive and negative connections. ↓ is a reference pin.

The following features are available when communicating on an RS-485 Automation Level Network:

- RS-485 port
- Virtual AEM

Without additional hardware, the Virtual AEM connects an RS-485 APOGEE Automation Level Network (ALN) or individual RS-485 field panels to a P2 Ethernet network.

- An additional license is required.
- FLN support is not available when a Virtual AEM license is installed.

2.2.3.1 FLN Support

The Siemens Industry Field Level Network (FLN) can consist of devices that communicate over an RS-485 connection using either MS/TP or Protocol 1 (P1).

- BACnet/IP ALN networks support application-specific control devices that communicate using MS/TP or P1.
- Ethernet TCP/IP and RS-485 ALN networks only support application-specific control devices that communicate using P1.

PXC Modular Series FLN Support.				
ALN Protocol	FLN Protocol Supported	Firmware Revision	Number of FLN Devices ¹	Drop Number Range
BACnet/IP	MS/TP or P1 (RS-485)	3.1 and later	Up to 96 devices per FLN connection	0 to 254
Ethernet TCP/IP or RS-485	P1 (RS-485)	2.8.5 and later	Up to 96 devices per FLN connection	0 to 254
		2.8.4 and earlier	32 devices per FLN connection	0 to 31 if networked 0 to 99 if stand-alone

¹ Each field panel supports a total of 96 FLN devices. With Firmware Revisions 2.8.5 and later, the devices may be grouped in any combination on the FLN ports as long as the total number of FLN devices on the field panel does not exceed 96.

2.2.4 Expansion Module Overview

The Expansion Module provides the hardware connection for Field Level Network (FLN) devices including:

- Siemens Industry FLN
- Communications Drivers to Non-Siemens Networks
- Wireless P1 FLN

2.2.4.1 Siemens Industry FLN

Using the Triple RS-485 Expansion Module, the PXC Modular supports up to three RS-485 networks of P1 Field Level Network devices, or one RS-485 network of BACnet MS/TP devices.

2.2.4.2 Communication Drivers to Non-Siemens Networks

As an option, the PXC Modular can communicate to related building system controllers, such as boilers, chillers, rooftop units, Programmable Logic Controllers (PLCs), power meters, lighting panels, fire alarm and life safety systems, and access control systems.

2.2.4.3 Wireless P1 FLN

Wireless P1 FLN replaces the traditional FLN cabling with wireless communication links that form a wireless mesh network. The Wireless FLN is enabled through the PXC Modular HMI.



NOTE:

A P1 FLN license must be installed in order to use Wireless FLN.

2.2.5 TX-I/O Island Bus

The PXC-36 offers the flexibility of expanding the total point count through a self-forming island bus. With the addition of TX-I/O modules and a TX-I/O Power Supply, up to 32 points (or four TX-I/O modules) can be supported.

An additional license may be required to enable the Island Bus.

Modular Series Smoke Control Application Requirements

- The controller must be located at the bottom of the enclosure.
- The controller may be oriented either horizontally or vertically. See the following figures.

For Ethernet communications, the UL Listed surge protector (Ditek model DTK-MRJ45C5E) is required for BACnet/IP or Ethernet TCP/IP (P2) networks. The surge protector must be located in the same enclosure as the controller.

Modem Requirements

- The UL864 Listed surge protector (538-600) is required.
- Devices connected between the USB port and the UL Listed surge protector must be located within the same room.
- A USB-to-RS-232 adaptor may be needed for UL Listed modems or UL Listed printers that are not configured for USB communication.
- The modem may be located inside the PX Series enclosure.

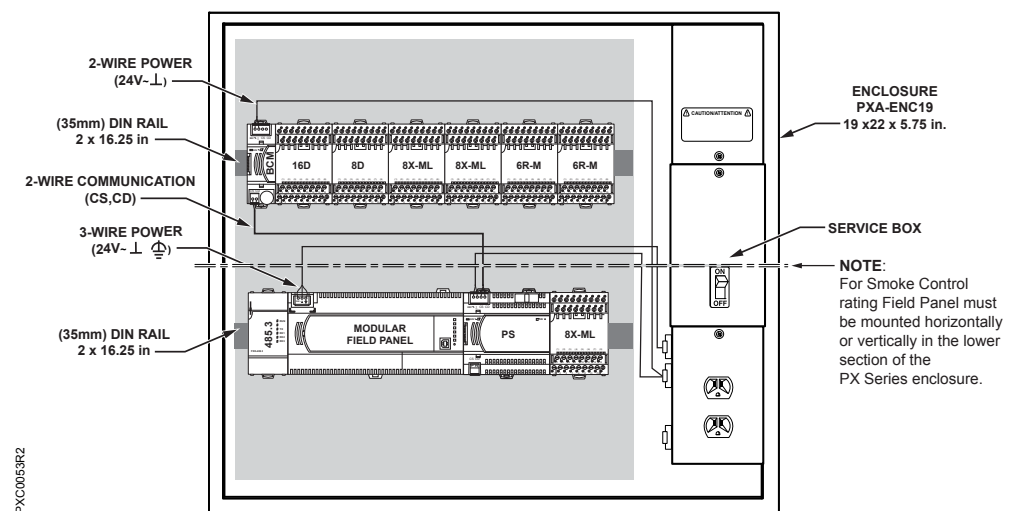

Figure 4:

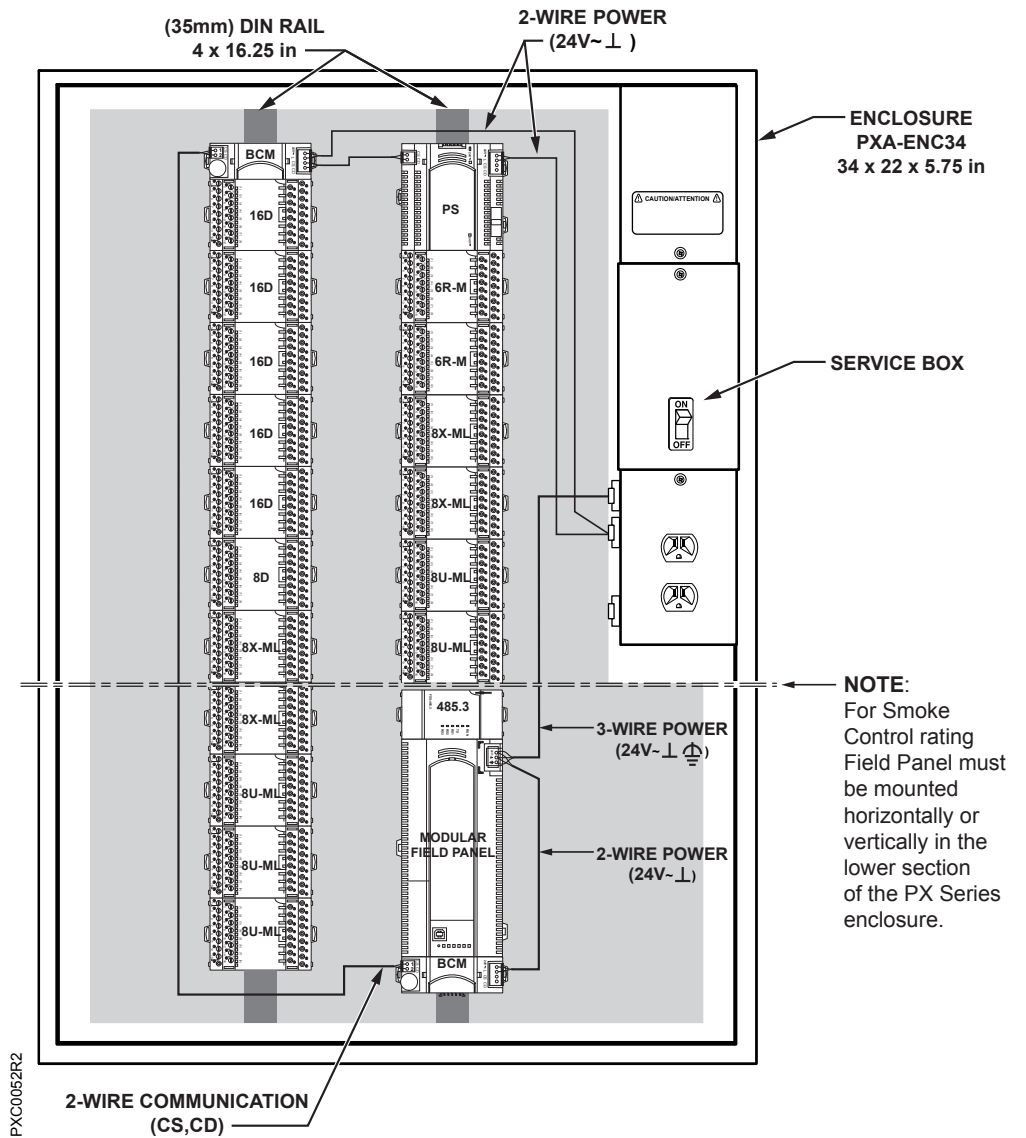

Figure 5:

Example ALN Configuration for Smoke Control Applications

The RS-485 ALN does not have the same restrictions as the Ethernet ALN for smoke control. Namely, Ethernet requires UL listed switches and routers.

The following figure displays a possible ALN configuration for smoke control.

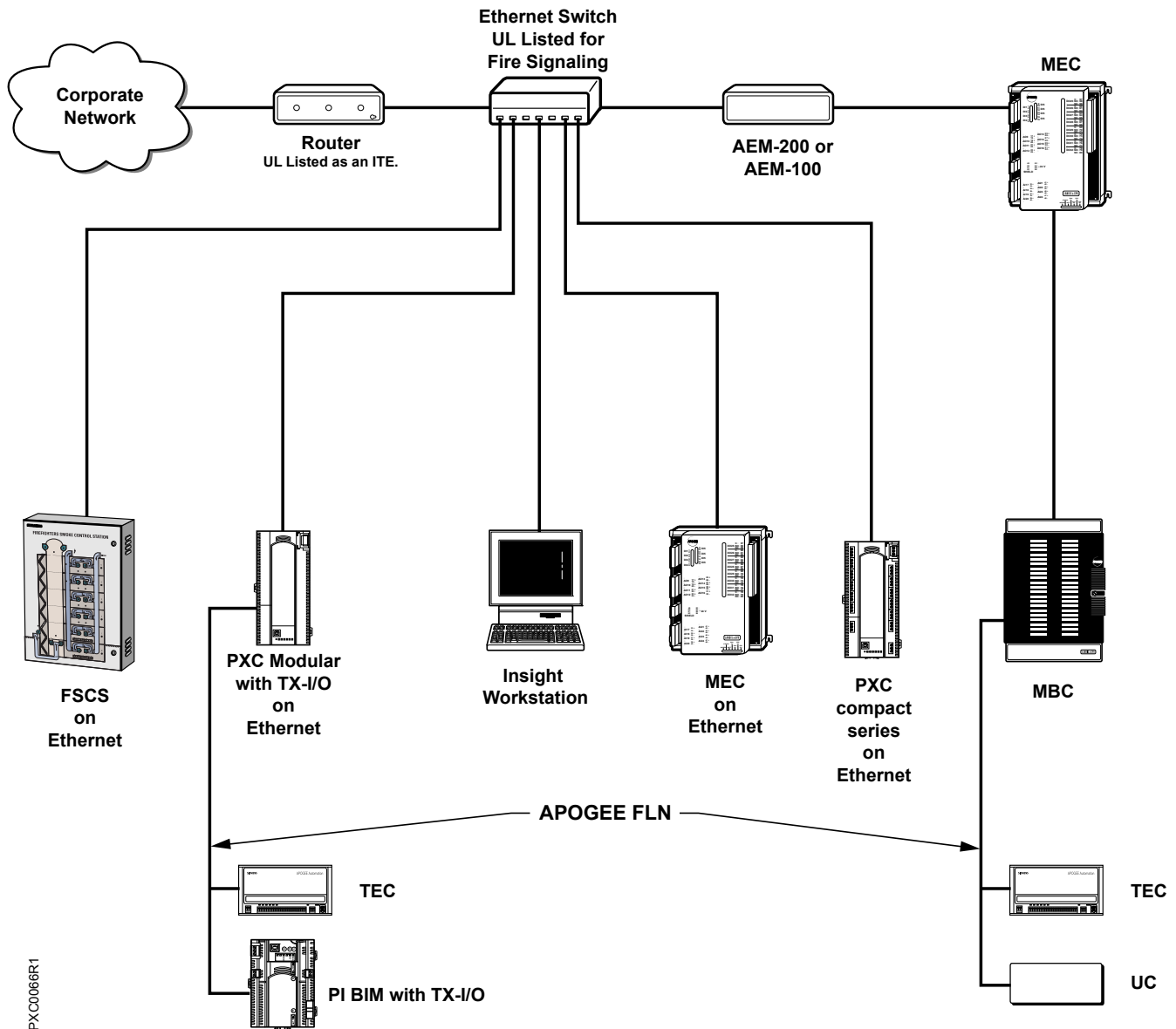

Figure 6: Example ALN Configuration for Smoke Control.

PXM10S/T Product Overview and Description



NOTE:

All figures show the BACnet version of the PXM10S and PXM10T. The appearance of the proprietary version may differ slightly.

PXM10S and PXM10T are optional controller mounted Operator Display modules that provide a password protected user interface. This interface allows you to interact with the existing field panel database and its immediate sub-networked Siemens (FLN) devices. (Optional remote enclosure door mount kit also available.)



NOTE:

All unacknowledged alarms are viewable even if you are not logged into the module.

Product Description

The PXM10S and PXM10T modules are available as an upgrade for use with all Siemens Compact and Modular Series field panels to provide additional local operator capabilities. The PXM10S and PXM10T modules are field mounted and replace the field panel covers.

There are three dedicated buttons, ALARM, INFO, ESC and one push DIAL. These buttons, the push dial, and LCD display screen allow for interactive feedback at the field panel controller.

The PXM10S and PXM10T modules support all the languages loaded in the host field panel.

There are two versions of the modules as follows:

- PXM10S has all available options, including Point Monitor and optional blue backlight color.
- PXM10T does not include the Point Monitor or the optional blue backlight color.

Language selection and user account timeout settings are configurable using an operator workstation or HyperTerminal at the field panel's HMI.

All PXM10S/T preferences are panel-specific and stored in the local panel configuration data.



NOTE:

For more information on creating and configuring user accounts, see the *APOGEE P2 ALN Field Panel User's Manual* (125-3019) or *APOGEE BACnet ALN Field Panel User's Manual* (125-3020).

Product Features

The PXM10S and PXM10T modules provide the following features:

- Plug and Play - Upon connection to the host field panel, the device is recognized and fully functional.
- Hot Swappable – The module can be installed or removed without powering down the controller and interrupting facility operations.
- User-friendly navigation and menu structure.
- Push DIAL for easy operation.
- Alarm button with red LED indicator for local alarm annunciations.
- INFO button provides one touch access to detailed system information for points.
- Manual and automatic login option for enhanced security or easy access.
- View point information and status, view and acknowledge alarms, and command/release local field panel points.
- Point Monitor – Can customize a group of points to continuously display and refresh with updated values (PXM10S only).
- Multi-language (English, Simplified Chinese, French, and Korean) support.

- The PXM10S and PXM10T modules can also be mounted on the inside or outside of an enclosure door, using an optional accessory sold separately.

Communication Connections

A field panel fully powered and running Firmware Revision 2.8.6/3.2.2 or later, recognizes the PXM10S and PXM10T modules within approximately 5 seconds of connection. Prior to that, the Operator Display is not operational.

If a field panel is coldstarted or it's the first time the panel is powered up, it takes approximately 15 to 30 seconds after connection before the PXM10S and PXM10T module is operational.

Requirements

System Requirements

The PXM10S and PXM10T modules can be used with Compact platforms (PXC-36, PXC-24, and PXC-16) as well as the PXC Modular field panels.

- All hardware must be installed.
- Power must be available to all devices.
- System components must be installed, running, and checked out by an appropriate system representative.

Hardware Platform

The PXM10T and PXM10S modules can be used on all Siemens Compact and Modular series controllers. An additional connecting ribbon cable (part number PXA-HMI.CABLEP5) is required when mounting to a PXC16 or PXC24.

Firmware Platform

The PXM10T and PXM10S modules are compatible with all Siemens Compact and Modular series controllers using Firmware Revision 2.8.6/3.2.2 or later (proprietary protocol/BACnet).

Application Menus

The following application menus are provided with the PXM10S and PXM10T modules.

- Login
- Alarms
- Points (Command and Release)
- Point Monitor
- Logoff
- Settings



NOTE:

You must have sufficient operator access permissions to the Alarms, Points, and Point Monitor applications to fully use all features and corresponding submenus.

Operator Display Layout

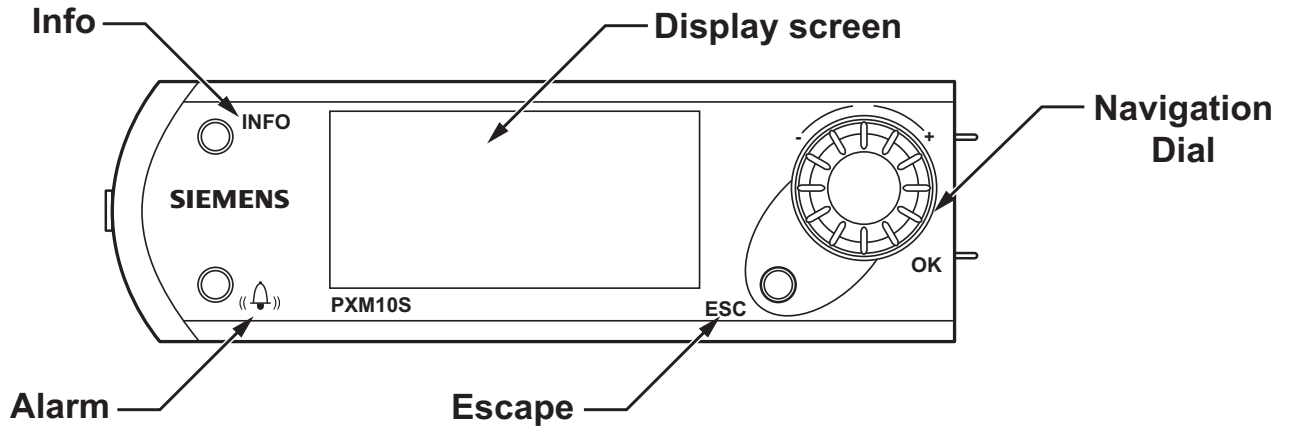

PXM0011R1

Display screen – Displays splash screen with either PXM10S or PXM10T module, device Firmware Revision, field panel Firmware Revision number, and Cimetrics BACstac revision number. Cursor position is indicated by either a right-angled bracket (>) or inverted text color, depending on field panel type and revision.

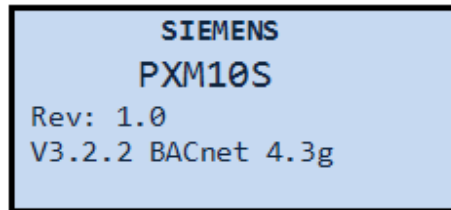

Figure 7: Splash Screen



NOTE:

If text information is too long for the display screen, the text scrolls horizontally across the screen, in a marquee style. If a high-priority task (such as a back-up) is being performed, the horizontal scrolling may be erratic.



NOTE:

The list of objects (once it is created) that displays for the Alarms, Points, and Point Monitor menus is static, however, the point information (current value, status, priority, etc.) is dynamic. You must leave the menu/page and return to it in order to view any updated information.

Navigation Push DIAL – Rotate clockwise or counter clockwise to highlight menu options (up or down). Press the dial to enter a menu or to make a selection. Rotate the dial to change a value. Pressing the dial is equivalent to selecting **OK**.

ESC button – Press once to return to previous menu/page or backspace during text/value editing.

INFO button – Press once to navigate to the window containing all available information about the point on selected line.

Alarm Window

There are two ways to view alarms, both of which display the alarm list with the point system name and status:

- **Alarm button.** Provides direct access to the list of unacknowledged alarms.
- **Alarm menu.** Displays any point in alarm, regardless if it has been acknowledged or not and provides three generic filters:
 - Unacknowledged Alarms filter allows you to filter all alarms and lists only unacknowledged alarms in local system.
 - All Alarms filter allows you to view all acknowledged and unacknowledged alarms in the system.
 - Failures/Faults filter allows you to view all failures/faults in the system for which alarming has been enabled.

Pressing the **INFO** button for point information displays:

U8	
System Name	U8
Ack Pendi	Ack Pendi
OFFNORMAL	Enabled
Time	09:46:45

Figure 8: INFO for Alarms

Press **ESC** to close alarm window without affecting the alarm.

Operator Display Menu Tree

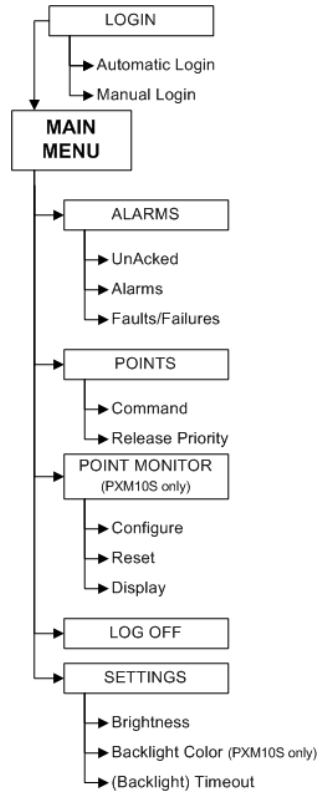

Main Menu Structure

All menu screen captures in this manual reflect the PXM10S module. Not all menu options/features shown are available with the PXM10T module.



NOTE:

A solid DOWN arrow in the top right corner of the display screen indicates more menu options are available and a solid UP arrow indicates more items are available after the last highlighted item.

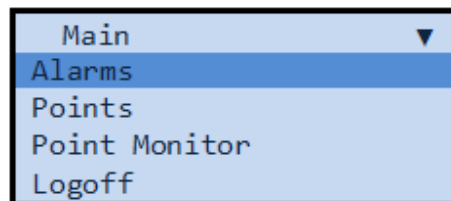

Figure 9: Main Menu

Alarms - Allows you to view and acknowledge alarms and failures/faults. However, you must be logged in with sufficient permissions (at least Command or Edit/Configure level access) to acknowledge an alarm.

Points - Allows you to view, command, and release the host field panel's onboard points and sub network points (FLN devices). To command and release points, you must have Command or Edit/Configure level access permissions.

Point Monitor - Displays a submenu, which allows an operator to configure and display a custom grouping of point and their values. The values are refreshed every four seconds. To configure points, you must have Edit/Configure level access permissions.

LogOff - Displays screen for confirming logoff.

Settings - Displays a submenu and screens that allow you to customize the LCD's display settings.

Login and Logoff

You must have at least Read Only level access permission to login to the PXM10S or PXM10T module. If you log in and you have no access level permissions, the system will immediately log you off the module.

After three failed login attempts, the user account will be locked. An administrator must use the HMI to unlock the user accounts by modifying that particular user account. Also, you can only change your password for the PXM10S or PXM10T modules from the HMI.

Logging In

Automatic Login

The PXM10S or PXM10T automatic login feature must be configured using the host field panel's HMI port. Only one user account can be flagged as the automatic login account.



NOTE:

Default user account login information for PXM10S or PXM10T is on a per ALN account basis.

If your network contains an assortment of field panels with Firmware Revisions earlier than 2.8.6/3.2.2, the AutoLogin account is not replicated or passed onto other field panels. For more information about workstation user accounts, see the *Insight Online Help* system.

Configuring AutoLogin at the HMI with HyperTerminal

Complete the following steps to configure an automatic login using HyperTerminal at the host field panel's HMI.

You must be logged into the field panel with an account that has Edit level access permission to the users access group.

To configure automatic login, complete the following steps:

HMI	S, U, A, E, A (System, Users, Accounts, Edit, Add)
------------	---

Prompt/Field	Option/Entry	Description
User initials		Type the new user's initials.
Account name		Type the account name.
Password		Type a password for the user.
Verify password		Retype the password.
System, User namespace	S	View System point names.
	U	View User point names. (default setting)
Access group(s)	All groups	(default setting)
	A single access group	Valid value 1 through 30.
	Multiple access groups	Valid values 1 through 30 separated by commas, or use two periods to indicate a range (for example, 1..4,7,9,12..20).
Privilege NOTE: Auto User accounts need access to Point and Alarm ONLY.	Point	N (No_access) R (Read_only) C (Command) E (Edit) (default setting)
	Alarm	N (No_access) R (Read_only) C (Command) E (Edit) (default setting)
	Trend	N (No_access) R (Read_only) C (Command) E (Edit) (default setting)
	Application	N (No_access) R (Read_only) C (Command) E (Edit) (default setting)
	PPCL	N (No_access) R (Read_only) C (Command) E (Edit) (default setting)
	FLN devices	N (No_access) R (Read_only) C (Command) E (Edit) (default setting)
	Equipment Scheduler	N (No_access) R (Read_only) C (Command) E (Edit) (default setting)
	System	N (No_access) R (Read_only) C (Command) E (Edit) (default setting)
	Diagnostics	N (No_access) R (Read_only) C (Command) E (Edit) (default setting)
	Users	N (No_access) R (Read_only)

		C (Command) E (Edit) (default setting)
	Hardware	N (No_access) R (Read_only) C (Command) E (Edit) (default setting)
Language ID	Language	Default
	Particular language	Language ID, ? displays all available languages. NOTE: You can also enter nothing, to display all available languages.
Time format	(HH:MM:SS)	Default
	Particular format	Time format; ? displays all available formats. NOTE: You can also enter nothing, to display all available Time formats.
Date format	(MM/DD/YYYY)	Default
	Particular format	Date format; ? displays all available formats. NOTE: You can also enter nothing, to display all available Date formats.
AutoLogoff enabled (Y/N)	Y	Enable automatic logoff.
	AutoLogoff delay	1 to 1440 minutes
	N	Disable automatic logoff.
Password Expire Limit		0 to 365 days
Use for PXM10Tiny AutoLogin (Y/N)	Y	Enable automatic login.
	N	Disable automatic login.

Example

```

>User initials           : tiny
>Account name           : PXM10TINY-----
---
>Password               : ?????-----
>Verify password       : ?????-----
>System, User namespace : U
>Access group(s)       : 1..30-----
-----
>Point privilege - No_access, Read_only, Command, Edit: E
>Alarm privilege - No_access, Read_only, Command, Edit: E
>Trend privilege - No_access, Read_only, Command, Edit: E
>Application privilege - No_access, Read_only, Command, Edit: E
>PPCL privilege - No_access, Read_only, Command, Edit: E
>FLN devices privilege - No_access, Read_only, Command, Edit: E
>Equipment Scheduler privilege - No_access, Read_only, Command,
Edit: E
>System privilege - No_access, Read_only, Command, Edit: E
>Diagnostics privilege - No_access, Read_only, Command, Edit: E
>Users privilege - No_access, Read_only, Command, Edit: E

```

```
>Hardware privilege - No_access, Read_only, Command, Edit: E
>Language ID                : 0409
>Time format                 : HH:MM:SS---
>Date format                 : MM/DD/YYYY-
>AutoLogoff enabled (Y/N)   : Y
>AutoLogoff delay           : 5---
>Password Expire Limit      : 30-
>Use for PXM10Tiny AutoLogin (Y/N): Y
User account <tiny> added
```



NOTE:

For more information on creating and configuring user accounts, see the *APOGEE P2 ALN Field Panel User's Manual* (125-3019) or *APOGEE BACnet ALN Field Panel User's Manual* (125-3020).

Do the following to automatically log in to the PXM10S or PXM10T module.

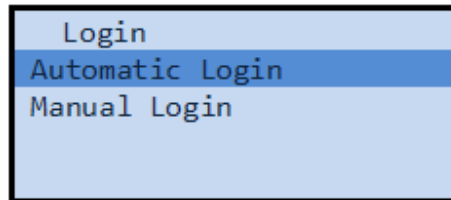

Figure 10: Automatic Login Submenu

Menu/Submenu	Step	Description
Splash screen/logo	Press the dial.	
	Rotate the dial to highlight Automatic Login .	Login menu displays.
Login	Press the dial to select Automatic Login .	System logs you into the Main menu of the module.

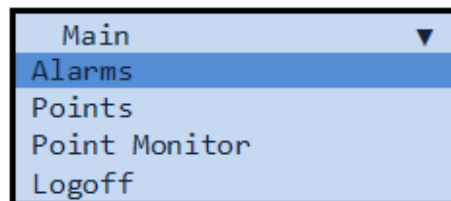

Figure 11: Main Menu

Manual Login

Do the following to manually log in to the PXM10S or PXM10T module. The default language for manual login is U.S. English.

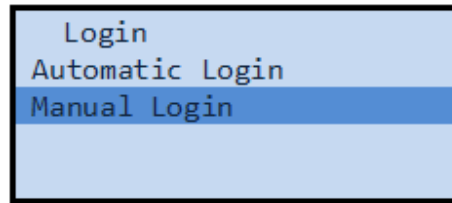

Figure 12: Manual Login Submenu

Menu/Submenu	Step	Description
Splash screen/logo	Press the dial.	
	Rotate the dial to highlight Manual Login .	Login menu displays.
Login	Press the dial to select Manual Login .	Displays the Manual Login submenu.
Manual Login	USR **** PWD *****	Enter your user name (up to 4 characters) and password (3 to 15 characters). A one character username is allowed. NOTE: You can only use capital letters A through Z for user name and passwords.
	For USR , rotate the dial to highlight each character.	
	Press the dial to select each character. Repeat until you enter the complete user name.	NOTE: If you make a mistake selecting a character, press ESC to return to the previous character.
	Press the dial twice to move to the PWD fields.	
	For PWD , rotate the dial highlight each character.	
	Press the dial to select a character. Repeat until you enter the complete password.	NOTE: If you need to return to the previous editable field, for example from PWD fields back to USR fields, press ESC . To proceed to the next field, press the dial.
	Press the dial to confirm USR and PWD.	System logs you into the Main menu of the module.

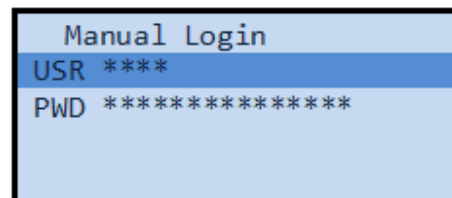

Figure 13: Manual Login Screen

Logging Off

There are three ways to log off.

- Automatic logoff – Occurs when the module interface has been idle for the amount of time defined in the user account settings. The timer feature is configured when a user account is created at the field panel.
- Manual logoff – Select **Logoff** on the screen – Prompts you to confirm logoff.
- Press **ESC** on the Main menu screen – Prompts you to confirm logoff.



NOTE:

When you log off the module, the screen may go blank for approximately two seconds.

Do the following to manually log off the PXM10S or PXM10T module.

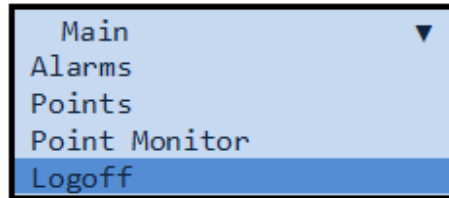

Figure 14: Logoff Menu

Menu/Submenu	Step	Description
Main	Rotate DIAL to highlight Logoff .	
	Press DIAL/OK to and select Logoff .	Displays the Logoff submenu.
Confirm Logoff Are you sure?	Rotate DIAL to highlight Yes or No .	
	Press DIAL/OK to make selection.	Confirms logoff and returns to splash screen. NOTE: If you press ESC , you are prompted with the same Confirm Logoff screen.

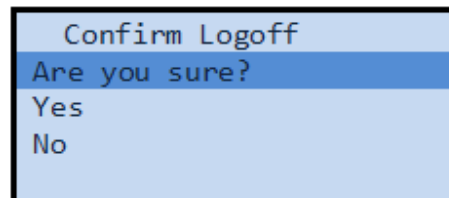

Figure 15: Confirm Logoff Submenu

Viewing, Commanding, and Releasing Points

Viewing Points

All points displayed on the screen are listed alphabetically, by system name.



NOTE:

Only four lines (excluding the title) of points are listed at a time for the English and French language.

Only three lines (excluding the title) of points are listed for the Chinese and Korean language.

Do the following to view and scroll to the next series of points in the field panel.

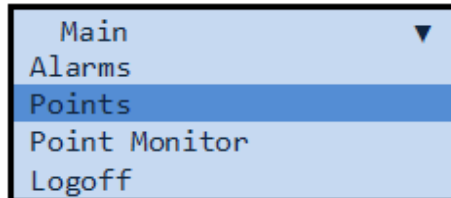

Figure 16: Points

Menu/Submenu	Step	Description
Main	Rotate DIAL to highlight Points .	
	Press DIAL/OK to select Points .	Displays the Points menu.
Points	Press DIAL/OK to highlight desired point.	
	Press DIAL/OK to select point.	
	Rotate DIAL to highlight the last point (bottom of screen), and then rotate DIAL once more.	Refreshes the screen and displays the previous screens last highlighted point, as well as the next series of points.
	Repeat steps until you reach the end of the point list.	The number of points you can enter is dependent on the number of points stored at the host's field panel database, and sub network devices connected/configured to the host's field panel you are connected to.
	Press ESC .	Returns you the Points menu.
	Press INFO .	Displays detailed point information of selected point.

Points ▼	
stName:Address	41943
U7	5.01
U8	7.51
X5	5.00

Points ▲	
U7	5.01
U8	7.51
X5	5.00
X6	7.50

Scrolling the List of Points

The point name is displayed in the left column and values in the right column.

The PXM10Tiny on proprietary firmware will display point status as well as value. BACnet firmware will display value only.

For TECs, the prefix is the TEC name; and the exposed point in the Points menu is the DAY.NGT subpoint. To see a complete list of the device’s subpoints, highlight the DAY.NGT point, and then press DIAL/OK.

Points ▼	
EUT:Address	41943
t1:DAY.NGT	DAY
U7	N
U8	N

t1 ▼	
APPLICATION	2092
ROOM TEMP	74.00
RM STPT DIAL	74.00
AUX TEMP	74.00

TEC Subpoints Menu with List of Device Subpoints



NOTE:

Based on FLN speed and network traffic, there may be a delay in displaying a full point database.

Commanding Points

Do the following to change the point value and command the points in the field panel. These steps also apply to commanding TEC subpoints.

Point Action ▼	
Command	
Release Priority	

Figure 17: Point Action Command Submenu

Menu/Submenu	Step	Description
Main	Rotate DIAL to highlight Points .	
	Press DIAL/OK to select Points .	Displays the Points menu.

Menu/Submenu	Step	Description
Points	Press DIAL/OK to highlight desired point.	Displays the Point Action Command submenu.
Point Action	Rotate DIAL to highlight Command .	
	Press DIAL/OK to select Command .	Displays the point name in title. Lists the selected point's current value, edit (highlighted) and priority fields.
[selected point name]	With Edit field highlighted, rotate DIAL to each numeric character and decimal, and press DIAL/OK after each numeric increment, including decimal character, until you enter the new value.	Changes the specified point value.
	Press DIAL/OK .	Confirms the point value change and moves to the Priority field.
	With Priority field highlighted, repeat steps to change priority of selected point. NOTE: This field is BACnet-specific. P2 firmware always commands at a priority of OPER.	Confirms the point priority change and returns you to the Points menu.
	Press ESC .	Returns you to the previous menu without changing the point value or priority.

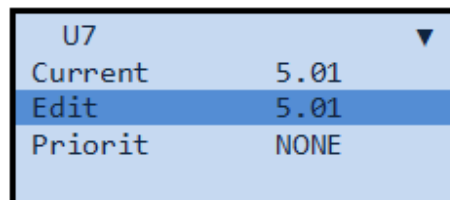

Figure 18: Command Point Value Submenu

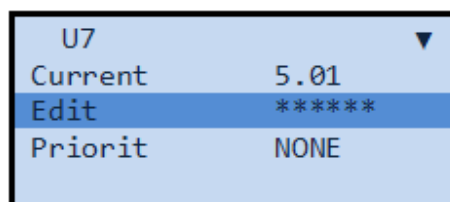

Figure 19: Edit Command Point Value Submenu

Releasing Points

Do the following to change a point priority and release a point.

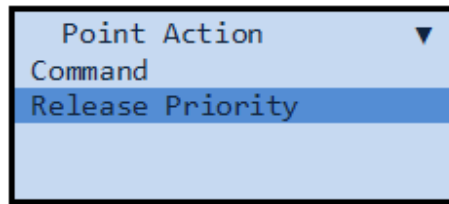

Figure 20: Point Action Release Priority Submenu

Menu/Submenu	Step	Description
Main	Rotate DIAL to highlight Points .	
	Press DIAL/OK to select Points .	Displays the Points menu.
Points	Rotate DIAL to highlight desired point.	
	Press DIAL/OK to select point.	Displays the Point Action Release Priority submenu.
BACnet Point Action	Rotate DIAL to highlight Release Priority .	
	Press DIAL/OK to select Release Priority .	NOTE: BACnet point priorities cannot be commanded lower than a priority value of 8.
	Rotate DIAL to change the numeric value of the point priority.	
	Press DIAL/OK to edit point priority.	
	Rotate DIAL to change point priority value.	
	Press DIAL/OK to confirm change.	Releases BACnet point priority.
	Press ESC .	Returns you to the previous menu without changing the point priority.
P2 Point Action:	Rotate DIAL to highlight Release Priority .	
	Press DIAL/OK to select Release Priority .	
	Rotate DIAL to select Yes or No. Press DIAL/OK .	This releases the priority to NONE.
	Press ESC .	Returns you to the previous menu without changing the point priority.

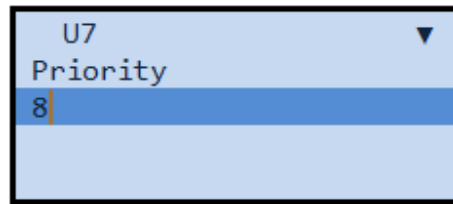

Figure 21: Release Priority Value Submenu

Configuring Point Monitor



NOTE:

This application and its sub-features are only available with the PXM10S module.

The Point Monitor allows you to select the points you frequently need to monitor and allows quick access to view a point status. This concept is similar to a Favorites list.

The maximum number of points listed and stored in Point Monitor is 10. You cannot add more points to the Point Monitor once you reach the maximum number.

Reset/clear the Point Monitor of stored points and then add the desired set of 10 or fewer points you want to monitor.



NOTE:

Depending on user access rights, previously added points (by other users) to the Point Monitor may not be visible. In this situation you can't see or add any points in Point Monitor. If this happens, you must first reset the Point Monitor to purge the old information. This affects all users. While Point Monitor information can't be retrieved, the field panel database is not affected.

Configuring Points for Point Monitor

Do the following to configure the host field panel's points for monitoring in Point Monitor after logging in.

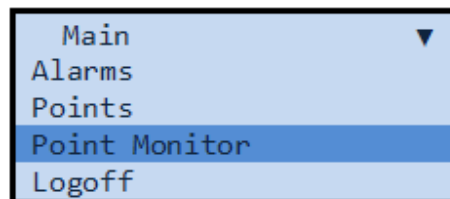

Figure 22: Point Monitor

Menu/Submenu	Step	Description
Main	Rotate DIAL to highlight Point Monitor .	
	Press DIAL/OK to select Point Monitor .	Displays the Point Monitor menu.

Menu/Submenu	Step	Description
Point Monitor	Rotate DIAL to highlight Configure .	Displays all available points at the field panel.
	Press DIAL/OK to select Configure .	
Edit Pt Monitor	Rotate DIAL to highlight desired point.	Displays black background, allowing you to edit field.
	Press DIAL/OK to select point.	
	Press DIAL/OK to select Y or N .	Y=Yes; point is monitored. N=No; point is not monitored. (This is the default setting.)
	Press DIAL/OK to select Y or N .	
	Press ESC .	Returns you to the Monitor menu.

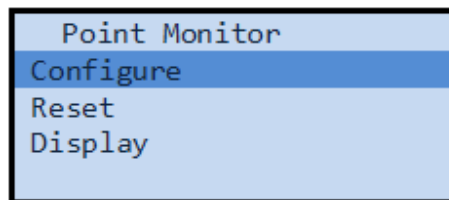

Figure 23: Configure Submenu

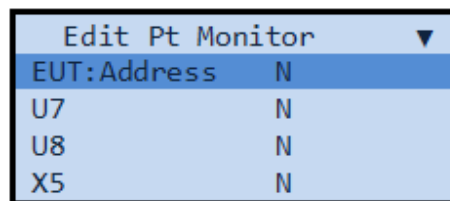

Figure 24: Edit Point Monitor Submenu

Do the following to configure bundled points in Point Monitor.

Menu/Submenu	Step	Description
Main	Rotate DIAL to highlight Point Monitor .	
	Press DIAL/OK to select Point Monitor .	Displays the Point Monitor menu.
Point Monitor	Rotate DIAL/OK to highlight Configure .	Displays all available points at the field panel.
	Press DIAL/OK to select Configure .	
Edit Pt Monitor	Rotate DIAL to select desired point.	Displays all available points and subpoints at the field panel.
Subpoints	Rotate DIAL to select subpoint.	Displays a list of subpoints associated with the selected point.

Menu/Submenu	Step	Description
	Press DIAL/OK to select Y or N .	Y=Yes; point is monitored. N=No; point is not monitored. (This is the default setting.)
	Press ESC .	Returns you to the Point Monitor menu.

Resetting Point Monitor

Do the following to reset points in Point Monitor.

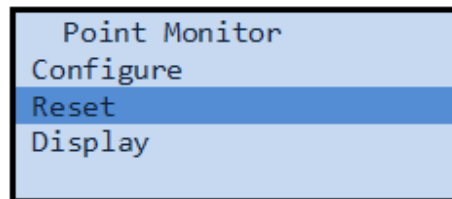

Figure 25: Reset Submenu

Menu/Submenu	Step	Description
Main	Rotate DIAL to highlight Point Monitor .	
	Press DIAL/OK to select Point Monitor .	Displays the Point Monitor menu.
Point Monitor	Rotate DIAL to highlight Reset .	
	Press DIAL/OK to select Reset .	Displays the Remove Monitor submenu.
Remove Monitor	Rotate DIAL to highlight point.	
	Press DIAL/OK to make select point.	
Remove Monitor Are you sure?	Rotate DIAL to highlight Yes or No .	Confirms you want to remove a point(s) from being monitored.
	Press DIAL/OK to make selection.	
	Press ESC .	Returns you to the Monitor menu.

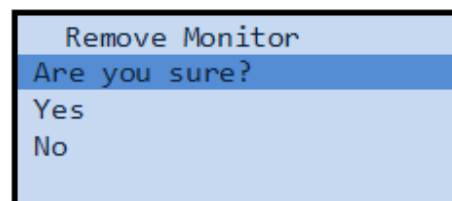

Figure 26: Remove Monitor Submenu

Displaying Monitored Points

Automatic logoff occurs after a predetermined amount of inactivity, however:

- The Point Monitor continues to display points and refreshes the Display screen every four seconds.
 - You can scroll the Point Monitor but the function keys (INFO, ESC, Alarm) are disabled.
 - If you press any of the key functions, the login splash screen prompts you to login.
- Do the following to display monitored points.

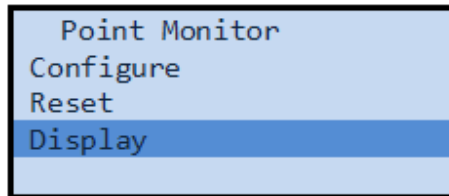

Figure 27: Display Submenu

Menu/Submenu	Step	Description
Main	Rotate DIAL to highlight Point Monitor .	
	Press DIAL/OK to select Point Monitor .	Displays the Point Monitor menu.
Point Monitor	Rotate DIAL to highlight Display .	
	Press DIAL/OK to select Display .	Displays the Display submenu.
Display		Displays the monitored points; one point and its value per line. Up to 10 points can be added the Point Monitor list.
	Press ESC .	Returns you to the Monitor menu.

Configuring Settings

Brightness

Do the following to modify the Brightness feature.

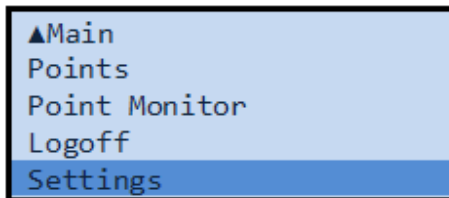

Figure 28: Settings Menu

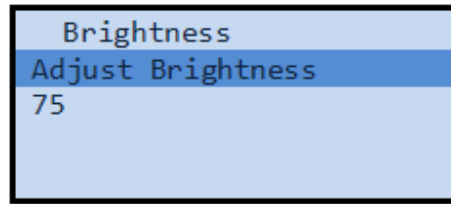

Figure 29: Adjust Brightness Submenu

Menu/Submenu	Step	Description
Main	Rotate DIAL to highlight Settings .	
	Press DIAL/OK to select.	Displays the Settings menu.
Settings	Press DIAL/OK to highlight Brightness .	
	Press DIAL/OK to select Brightness .	Displays the Brightness submenu.
Brightness	Rotate DIAL to highlight Adjust Brightness .	
	Press DIAL/OK to select Adjust Brightness .	
	Rotate DIAL to select a value.	Valid brightness values are 0 through 100.
	Press DIAL/OK to make selection.	Applies the value and returns you to the previous menu.
	Press ESC .	Returns you to the Settings menu without applying the new value.

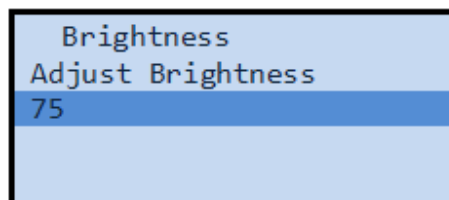

Figure 30: Brightness Submenu

Color



NOTE:

The Color feature is available only for the PXM10S module.

Do the following to modify the Color feature.

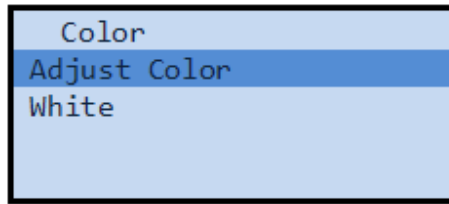

Figure 31: Adjust Color Submenu

Menu/Submenu	Step	Description
Main	Rotate DIAL to highlight Settings .	
	Press DIAL/OK to select.	Displays the Settings menu.
Settings	Press DIAL/OK to highlight and select Color .	Displays the Color submenu.
Color	Rotate DIAL to highlights and select Adjust Color .	
	Rotate DIAL to toggle between Blue and White color.	Displays the backlight color you choose.
	Press DIAL/OK to select.	Applies the value and returns you to the previous menu.
	Press ESC .	Returns you to the Settings menu without applying the new color.

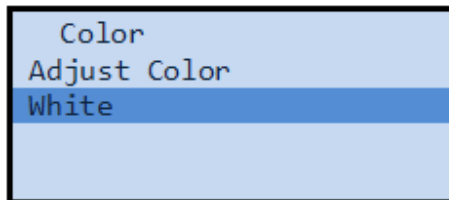

Figure 32: Color Submenu

Timeout

The PXM10S and PXM10T modules automatically turn off the backlight on the Display screen after a predetermined amount of inactivity. However, when you press any key, the backlight turns on again. If Point Monitor was active on the screen during this time, the point list is saved, even if you are logged off.

Do the following to modify the Timeout feature:

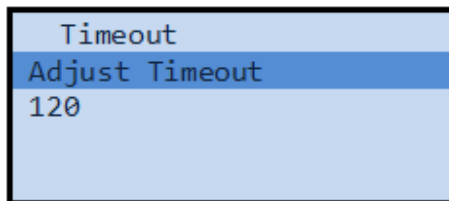

Figure 33: Adjust Timeout Submenu

Menu/Submenu	Step	Description
Main	Rotate DIAL to highlight Settings .	
	Press DIAL/OK to select.	Displays settings menu.
Settings	Press DIAL/OK to highlight and select Timeout .	Displays the Timeout submenu.
Timeout	Rotate DIAL to highlight and select Adjust Timeout .	
	Rotate DIAL to select a value.	Valid Timeout values are 0 through 240 seconds.
	Press DIAL/OK to select.	Applies the value and returns you to the previous menu.
	Press ESC .	Returns you to the Settings menu without applying the new value.

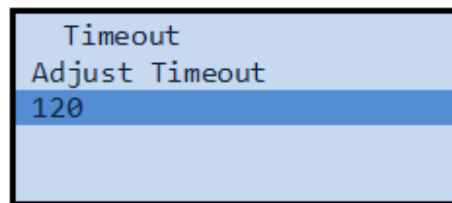

Figure 34: Timeout Submenu

2.3 TX-I/O Product Range Overview

TX-I/O is a range of I/O modules, with associated power and communication modules, for use within the APOGEE System. The I/O modules communicate between the PXC Modular or the PXC-36 and the related devices in the building services plant.

The TX-I/O product range includes the following:

- Eight types of I/O modules, which act as signal converters.
- TX-I/O Power Supply for the TX-I/O modules.
- TX-I/O Bus Connection Module, which bridges communication and power from one DIN rail to another.
- TX-I/O Island Bus Expansion (IBE) module, which increases the distance between the primary field panel and expansion field panels on the island bus.
- P1 Bus Interface Module (BIM), which connects TX-I/O modules to the P1 FLN. The P1 BIM provides power for TX-I/O modules, but it does not contain applications or perform control; the control database for the TX-I/O points resides in a field panel.

2.3.1 TX-I/O Module Overview

TX-I/O Modules are modular expansion I/O consisting of an electronics module and a terminal base; they receive power from a TX-I/O Power Supply, Bus Connection Module, or P1 BIM.

- The electronics module performs A/D or D/A conversion, signal processing, point monitoring, and command output.
- The terminal base provides for termination of field wiring and connection of the self-forming TX-I/O island bus.

All TX-I/O modules provide the following features:

- DIN rail mounting.
- High density point count (compared to physical dimensions).
- Hardware addressed with address keys.





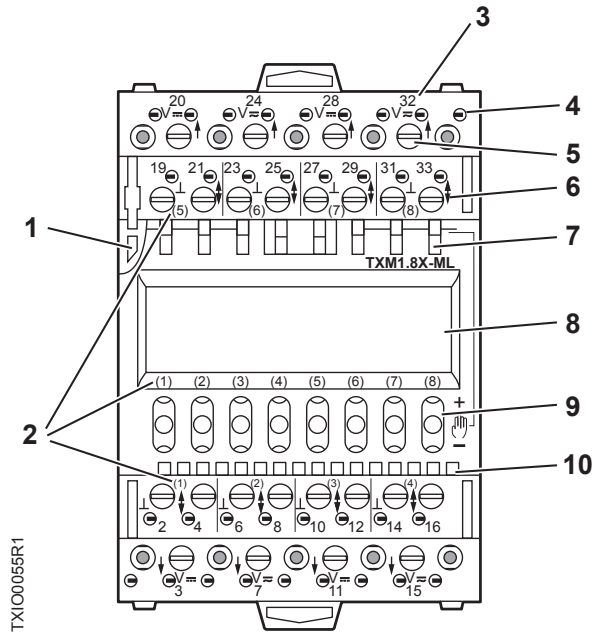

The design of the TX-I/O Modules provides optimum diagnostics and results in a more efficient installation and maintenance workflow.

- Field wiring may be terminated prior to installation of electronics.
- Connected peripheral devices can be measured without affecting or being affected by the I/O module.
- Hot-swappable electronic components allow powered electronics to be disconnected and replaced without removing terminal wiring or disturbing the self-forming bus.

2.3.1.1 TX-I/O Module Product Diagram





TX-I/O Module Symbols and Status LEDs			
	LED, Symbol, or Feature	LED or Symbol	Indication
1	Address key and module status LED (green)	-	Module status as a whole (as opposed to the I/O points).
		ON	Normal operation. 24 Vac (supply voltage) input present; fuse is intact.
		OFF	Error. - No 24 Vac (supply voltage) input. - Fuse is blown.

TX-I/O Module Symbols and Status LEDs			
	LED, Symbol, or Feature	LED or Symbol	Indication
		Flashing or pulsing	- Fault indication - No address key - Remote override
2	I/O point numbers	-	-
3	Terminal number	-	-
4	Test terminal	-	
5	Connection terminals	-	
6		-	System neutral.
		-	Configurable point.
		-	Output (arrow pointing OUT from center of module).
		-	Input (arrow pointing IN toward center module).
		-	24 Vdc output (field supply).
		-	24 Vac output (field supply).
7	Override status LEDs (yellow)	ON	Manual operation; a local override is active.
		OFF	No voltage or manual operation off.
		Flashing or pulsing	- Override action - Remote override - Output: Local override is off, operation is not possible. - Input: Operation is not possible.
8	LCD signal panel	-	Only on a TX-I/O modules with –ML suffix.
9	Local override switch	-	Only on a TX-I/O with –M or –ML suffix.
10	I/O status LEDs (green)	-	Status of the inputs and outputs (peripheral devices). LEDs are labeled with the I/O point number.
		ON	Binary value indication.
		OFF	No voltage or binary value indication.
		Flashing or pulsing	- Fault indication - Activity of field devices - Module unconfigured, no address key - Analog value indication

2.3.1.2 TX-I/O Module LCD Symbol Chart

The TX-I/O module LCD displays a symbol to indicate each point type and its current value.

TX-I/O Module LCD Panel for Errors and Reminders (Displays in LCD Top Row)	
	Value above range limit
	Value below range limit

TX-I/O Module LCD Panel for Errors and Reminders (Displays in LCD Top Row)	
	Open circuit
	Short circuit
	Point type invalid for use with manual override
	No sensor (current)
	No output signal
	24 Vdc supply < 22 Vdc
	Inactive point
	Invalid value
	No voltage
	Unconfigured point

TX-I/O LCD Panel by Point Type.			
Point Type (Displays in LCD Bottom Row)		Normal Operation (Displays in LCD Top Row)	
Analog Input, Current			Low or high value
Analog Input, Resistance			Temperature
Analog Input, Voltage			Low or high value
Analog Output, Current			Low or high value
Analog Output, Voltage			Low or high value
Digital Input, Counter			Step indicator
Digital Input, N/C Contact			
Digital Input, N/O Contact			

2.3.1.3 Address Keys

The P1 Bus Interface Module (BIM) (10-module) and I/O modules are addressed using a TX-I/O address key.

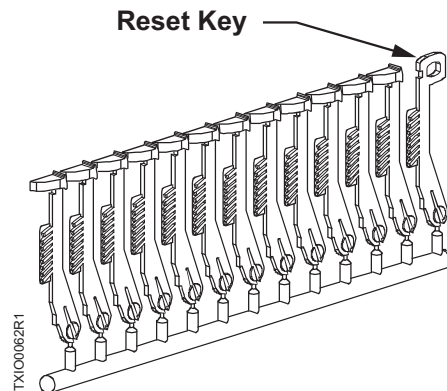

Figure 35: TX-I/O Module Keys.

The keys are available in sets of 24, up to a maximum value of 72 (2 sets of 12, 1-24, 25-48, and 49-72).

- The I/O module address is mechanically encoded in the address key.
 - Without an address key, the module is inactive.
 - With an address key inserted, the module has full functionality.
- Based on the address, the PXC Modular, PXC-36, or P1 BIM configures the I/O module, indicates which field devices are connected to this module, and which function is required for the field devices.

When replacing the plug-in I/O module, the address key must first be swiveled outward. This switches the load off but values remain saved in the PXC Modular, PXC-36, or P1 BIM. The key remains plugged into the terminal base so that the PXC Modular, PXC-36, or P1 BIM can communicate the required function to the new I/O module.

Reset Key

The reset key sets the module back to the factory settings (default function on each of the I/O points):

- The reset key is inserted in place of the address key and then swiveled out again.
- The module indicates the reset by briefly lighting all its I/O status LEDs.
- Note that a reset is only possible when the module is supplied with 24 Vdc.

TX-I/O Power Supply and Bus Modules

The TX-I/O Power Supply and Bus Modules provide power, communications, and expansion options for the TX-I/O Island Bus.

Power and Communication Modules

The TX-I/O Power Supply and Bus Connection Module provide the following functions for the island bus:

Product	Function		
	TX-I/O Bus Communication	24 Vdc power	24 Vac power
TX-I/O Power Supply (TXS1.12F4)	Signal pass-thru	Output 28.8 W (1.2A at 24 Vdc)	<ul style="list-style-type: none"> ● NEC Class 2 Output , 96 VA max., fused at 4A ● Class 1 Power Limited Input, 150 VA max.
Bus Connection Module (TXS1.EF4)	<ul style="list-style-type: none"> ● Signal pass-thru ● Allows for external connection of I/O signals. 	Pass-thru	<ul style="list-style-type: none"> ● NEC Class 2 Output, 96 VA max., fused at 4A ● Class 1 Power Limited Input, 96 VA max.

The P1 Bus Interface Module (BIM) provides the following functions for the island bus:

Product	Function		
	TX-I/O Bus Communication	24 Vdc power	24 Vac power
P1 Bus Interface Module (10-module) (TXB1.P1)	Protocol translation	14.4 W (0.6A at 24 Vdc)	<ul style="list-style-type: none"> ● NEC Class 2 Output, 96 VA max., fused at 4A ● Class 1 Power Limited Input, 125 VA max.
P1 Bus Interface Module (4-module) (TXB1.P1-4)	Protocol translation	14.4 W (0.6A at 24 Vdc)	<ul style="list-style-type: none"> ● NEC Class 2 Output, 96 VA max., fused at 4A ● Class 1 Power Limited Input, 125 VA max.

Island Bus Expansion Module

The Island Bus Expansion (IBE) module provides the following functions for the island bus:

Product	TX-I/O Bus Communication	Function
Island Bus Expansion Module (TXA1.IBE)	<ul style="list-style-type: none"> ● Signal pass-thru of Communication Data (CD) ● Allows for external connection of the I/O signals ● RS-485 interface 	Increases the distance between the primary field panel and expansion field panels on the island bus

TX-I/O Power Supply Overview

The TX-I/O Power Supply bridges communication and power from one DIN rail to another and generates 28.8 W (1.2A at 24 Vdc) to power TX-I/O modules and peripheral devices.

- An LED provides an indication of 24 Vdc on the TX-I/O bus.
- Up to 4 TX-I/O Power Supplies can be operated in parallel, with a maximum of two per DIN rail.
- It can be located within a row of TX-I/O modules or at the beginning of a new DIN rail.

The TX-I/O Power Supply performs the following functions:

- Transfers 24 Vac at 4A to power TX-I/O modules and peripheral devices.
- Provides an input point for 24 Vac to power additional peripheral devices.
 - Isolates the 24 Vac peripheral device supply in case of overload or short-circuit.
 - The replaceable AC fuse can be accessed from an installed module.
 - Indicates the AC fuse status with an LED for easy diagnostics.
- Routes the bus signal between DIN rails (+24 Vdc Communication Supply (CS) and Communication Data (CD) signals).

Supply Terminal Connections

- 24 Vac supply terminals are fused (replaceable) for Class 2 (24 Vac at 50/60 Hz) through the TX-I/O Power Supply.
- 24 Vdc supply terminals are connected in the I/O module, not in the terminal base. 24 Vdc is supplied and overload protected in the TX-I/O Power Supply.

Bus Connection Module Overview

The Bus Connection Module bridges communication and power from one DIN rail to another. It provides the bus signal, module supply voltage, and field device supply voltage to TX-I/O Modules on an additional DIN rail.

The Bus Connection Module performs the following functions:

- Passes 24 Vac at 4A to power TX-I/O modules and peripheral devices.
- Provides an input point for 24 Vac to power additional peripheral devices.
 - Isolates the 24 Vac peripheral device supply in case of overload or short-circuit.
 - The replaceable AC fuse can be accessed from an installed module.
 - Indicates the AC fuse status with an LED for easy diagnostics.
- Routes the bus signal between DIN rails (+24 Vdc Communication Supply (CS) and Communication Data (CD) signals).

Supply Terminal Connections

- 24 Vdc is supplied to terminals one and four (CS) and to both ends of the TX-I/O bus connector for distribution to connected TX-I/O modules and external devices.
- 24 Vac is passed through an internal fuse from terminals three and four (system neutral) to the male TX-I/O bus connector.
- External devices draw power from the 24 Vdc, 24 Vac, and system neutral terminals on the TX-I/O modules.
- 24 Vdc supply terminals are connected in the I/O module, not in the terminal base. 24 Vdc is current-limited in the Bus Connection Module.

Island Bus Expansion Module Overview

The TX-I/O Island Bus Expansion (IBE) module increases the distance between the primary field panel and expansion field panels on the island bus. Up to 4 expansion enclosures may be connected to the primary enclosure using IBEs, for a maximum of five IBEs on the island bus.

- Each IBE supports two segments of up to 200 ft (61 m) each.

- All expansion field panels must be connected to the same building approved earth ground as the primary field panel.
- Each IBE must be installed on the male bus connector of the TX-I/O Power Supply or a Bus Connection Module which is connected to a TX-I/O Power Supply.
- An LED provides an indication of island bus communication.
- A programming tool is not required.

For information on expanding an island bus with the IBE, contact your local Siemens Industry representative.

2.4 PX Series Enclosures and Service Boxes

PX Series enclosures house both electronic and pneumatic components. The enclosures include a perforated backplane for mounting PXC Series field panels or other electronic or pneumatic components.

General features of the enclosures includes:

- Availability in three sizes to match installation needs: 18-, 19-, and 34-inch.
- Sturdy construction, which accommodates secure conduit fittings and protects components against incidental contact and falling dirt.
- UL Smoke Control listed for indoor use (19- and 34-inch enclosures only).
- Multiple knockouts along the top and bottom.
- Perforated backplane, which extends wall-to-wall for mounting of additional equipment.
- Spacious interior for easy routing and termination of wiring.

The 18-inch enclosure is a pull-box type utility cabinet for low cost installations. It is equipped with the following:

- Factory-installed 16" × 12" perforated panel
- DIN rail and wire tie bar kit

The 19- or 34-inch PX series enclosures are equipped with the following:

- Factory-installed backplane assembly, which includes wire tie down rails and DIN rails
- Label pouch
- Hinged door and key lock
- Conduit knockouts and venting

2.4.1 PX Series Service Box Features

The PX Series Service Box Assemblies transform either 115 Vac or 230 Vac to 24 Vac sized for either 192 VA or 384 VA.

- The 192 VA service boxes mount directly inside a 19- or 34-inch PX Series Enclosure.
- The 384 VA service boxes provide additional power for larger systems and mount only in the 34-inch PX Series Enclosure.

The service boxes provide protection against electrical transients and are Smoke Control and Energy Management listed when installed according to the *Service Box Assemblies Installation Instructions* (553-131).

The service box assemblies consist of the following:

- Chassis for mounting inside enclosure.
- ON/OFF circuit breaker for transformer.
- Two Class 1 power limited 24 Vac outputs, which include one terminal for earth ground for use inside enclosure only.
- One Class 2 output with circuit breaker to distribute up to 96 VA for use outside the enclosure.
- Wire cover for field connections.
- Duplex Service Outlet (115 Vac models only).
- Optional sidewall kits PXA-SW192VA and PXA-SW384VA may be used for installation in third-party enclosures, such as motor control cabinets.

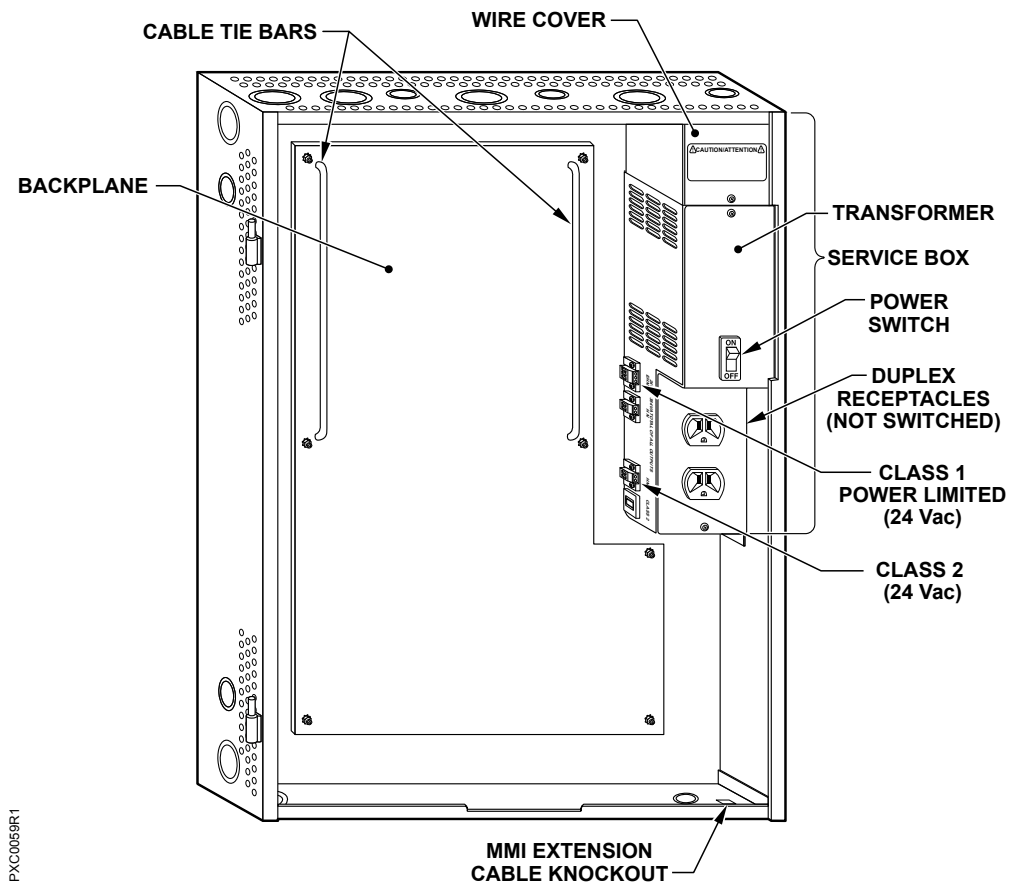

Figure 36: PX Series Service Box (115V), 34-inch enclosure.

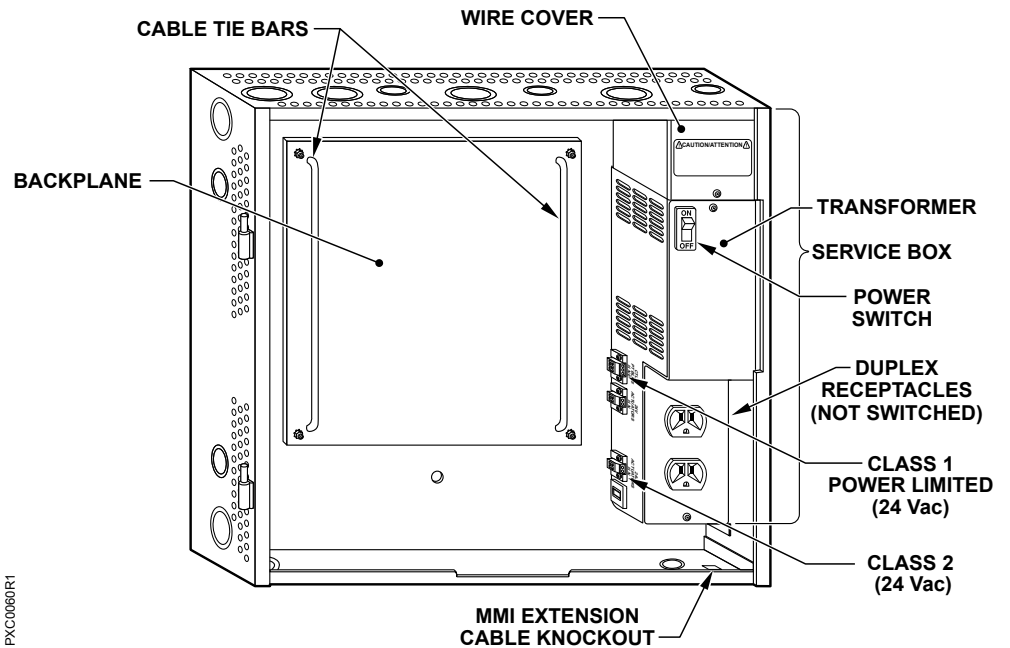

Figure 37: PX Series Service Box (115V), 19-inch enclosure.

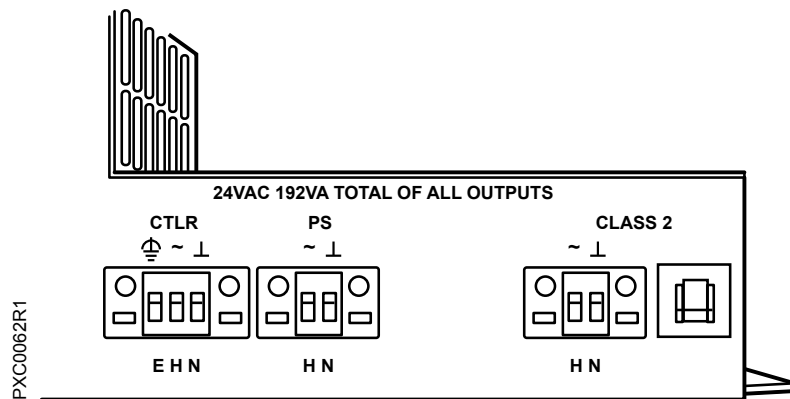

Figure 38: PX Series Service Box Connectors.

- Each Service Box distributes the total 24 Vac power provided to the plug-in terminations on the left side.
 - Two Class 1 power-limited terminations distribute up to the total power to controllers and power supplies inside the same enclosure.
 - Earth ground is provided on the CTRL termination.
 - One Class 2 termination distributes up to 96 VA to auxiliary devices outside of the enclosure.
- Each 115VAC Service Box has a duplex outlet on the front to power accessory devices such as modems and Portable Operator's Terminals.

2.4.2 Product Numbers

Product Number	Description
PXA-SB115V192VA	PX Series Service Box—115V, 24 Vac, 50/60 Hz, 192 VA
PXA-SB115V384VA	PX Series Service Box—115V, 24 Vac, 50/60 Hz, 384 VA
PXA-SB230V192VA	PX Series Service Box—230V, 24 Vac, 50/60 Hz, 192 VA
PXA-SB230V384VA	PX Series Service Box—230V, 24 Vac, 50/60 Hz, 384 VA
PXA-ENC18	18" Enclosure (Utility Cabinet) (UL Listed NEMA Type 1 Enclosure)
PXA-ENC19	19" Enclosure (UL Listed NEMA Type 1 Enclosure)
PXA-ENC34	34" Enclosure (UL Listed NEMA Type 1 Enclosure)

2.4.3 PX Series Enclosure Specifications

PX Series 18" Enclosure Specifications

Dimensions (H × W × D)

PXA-ENC18 18" × 14" × 6"
(457.2 mm × 355.6 mm × 152.4 mm)
UL Listed NEMA Type 1 Enclosure, Pull-box style

Operating Environment

Ambient operating environment +32°F to +122°F (0°C to +50°C), 95% rh (Non-condensing)

Mounting Surface Building wall or structural member (Do not mount on HVAC components or any other vibrating surface)

Agency Listings

Agency Compliance UL 508A (acceptable for UL 916 applications)
FCC Compliance

PX Series 19" and 34" Enclosure Specifications

Dimensions (H × W × D)

PXA-ENC19 19" × 22" × 5.75"
(482.6 mm × 558.8 mm × 146.05 mm)
UL Listed NEMA Type 1 Enclosure, Hinged Door with lock

PXA-ENC34 34" × 22" × 5.75"
(863.6 mm × 558.8 mm × 146.05 mm)
UL Listed NEMA Type 1 Enclosure, Hinged Door with lock

Operating Environment

Ambient operating environment +32°F to +122°F (0°C to +50°C), 95% rh (Non-condensing)

Mounting Surface Building wall or structural member (Do not mount on HVAC components or any other vibrating surface.)

Agency Listings

UL UL 864 UUKL Smoke Control Equipment
ULC-C100 UUKL7
UL 916 PAZX
UL 508A

Agency Compliance

FCC Compliance
Australian EMC Framework - with metal enclosure, maximum opening size is 34"
European EMC Directive (CE) - with metal enclosure, maximum opening size is 34"

European Low Voltage Directive (LVD)

2.4.4 PX Series Service Box Specifications

Power Requirements for 115 Vac Service Boxes

PXA-SB115V192VA
Input: 115 Vac +/- 15%, 50/60 Hz +/- 5%, 220 VA maximum, 2A CB
Output: 24 Vac +/- 20%, 50/60 Hz +/- 5%, 192 VA maximum

PXA-SB115V384VA
Input: 115 Vac +/- 15%, 50/60 Hz +/- 5%, 440 VA maximum, 4A CB
Output: 24Vac +/- 20%, 50/60 Hz +/- 5%, 384 VA maximum

115 Vac models also have a duplex outlet, which is protected by Mains 20A or 15A CB for use internal to enclosure to power laptop and peripheral devices.

Power Requirements for 230 Vac Service Boxes

PXA-SB230V192VA
Input: 230 Vac +/- 15%, 50/60 Hz +/- 5%, 220 VA maximum, 1A CB
Output: 24 Vac +/- 20%, 50/60 Hz +/- 5%, 192 VA maximum

PXA-SB230V384VA
Input: 230 Vac +/- 15%, 50/60 Hz +/- 5%, 440 VA maximum, 2A CB
Output: 24 Vac +/- 20%, 50/60 Hz +/- 5%, 384 VA maximum

Service Box Output Jacks

One 3-terminal and one 2-terminal NEC Class 1 output jack for use internal to enclosure to power system components.

One 2-terminal NEC Class 2 output jack with 4A CB for use external to enclosure to power actuators.

2.4.5 PX Series Enclosure Placement



CAUTION

Do not mount the enclosure on ductwork, HVAC components, or any other vibrating surface.

- Mount the enclosure at least 12 feet (3.7 m) away from devices that can generate Radio Frequency Interference (RFI), such as Electro-pneumatic devices (EPs), relays, and walkie-talkies.
- Mount the enclosure at least 5 feet (1.5 m) away from 100 kVa or larger motors and variable frequency drives (VFD).



CAUTION

If the enclosure is mounted under a wire trough or any other obstruction, provide a minimum vertical clearance of 2 inches (50.8 mm) to allow for installation and removal of the enclosure door.

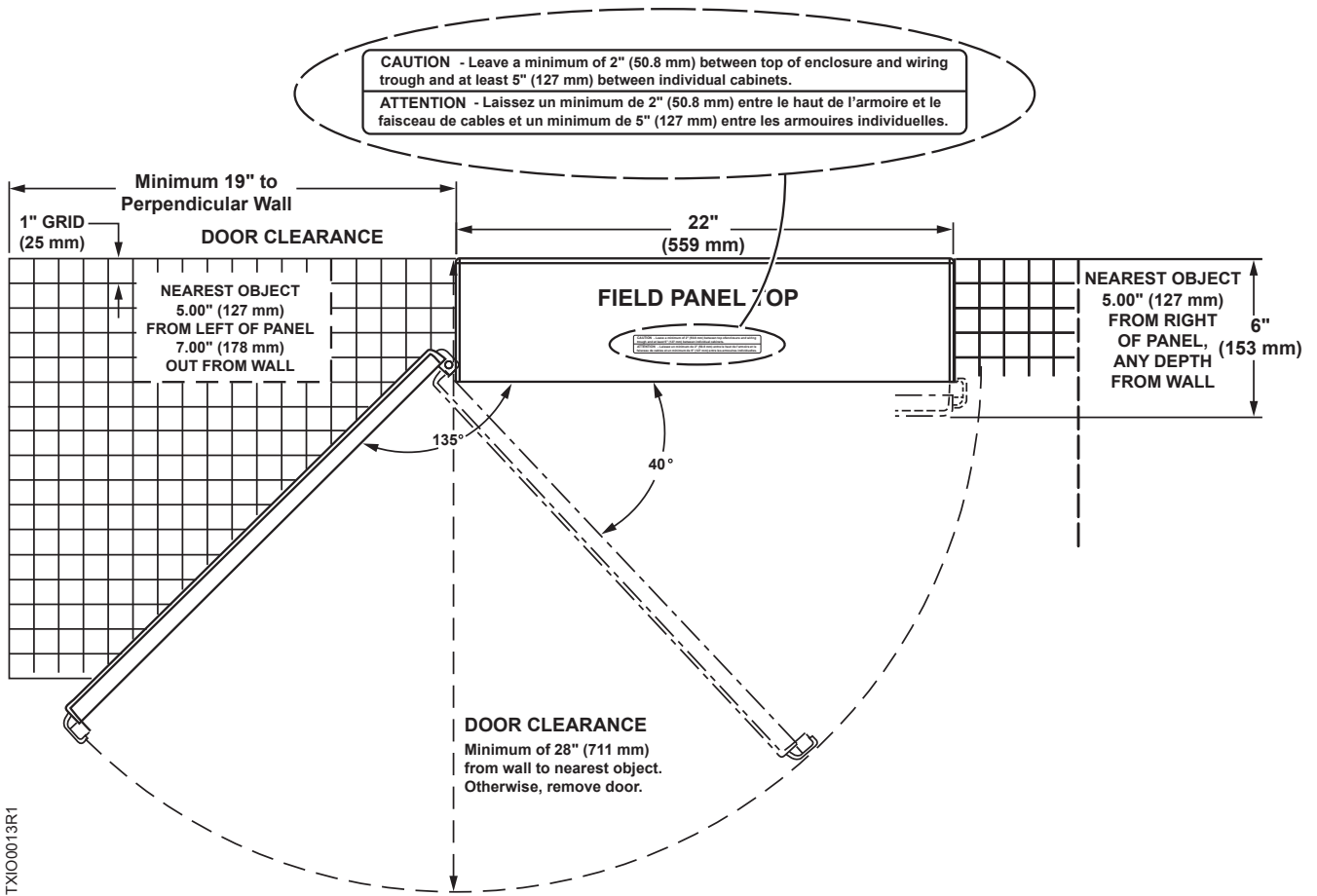

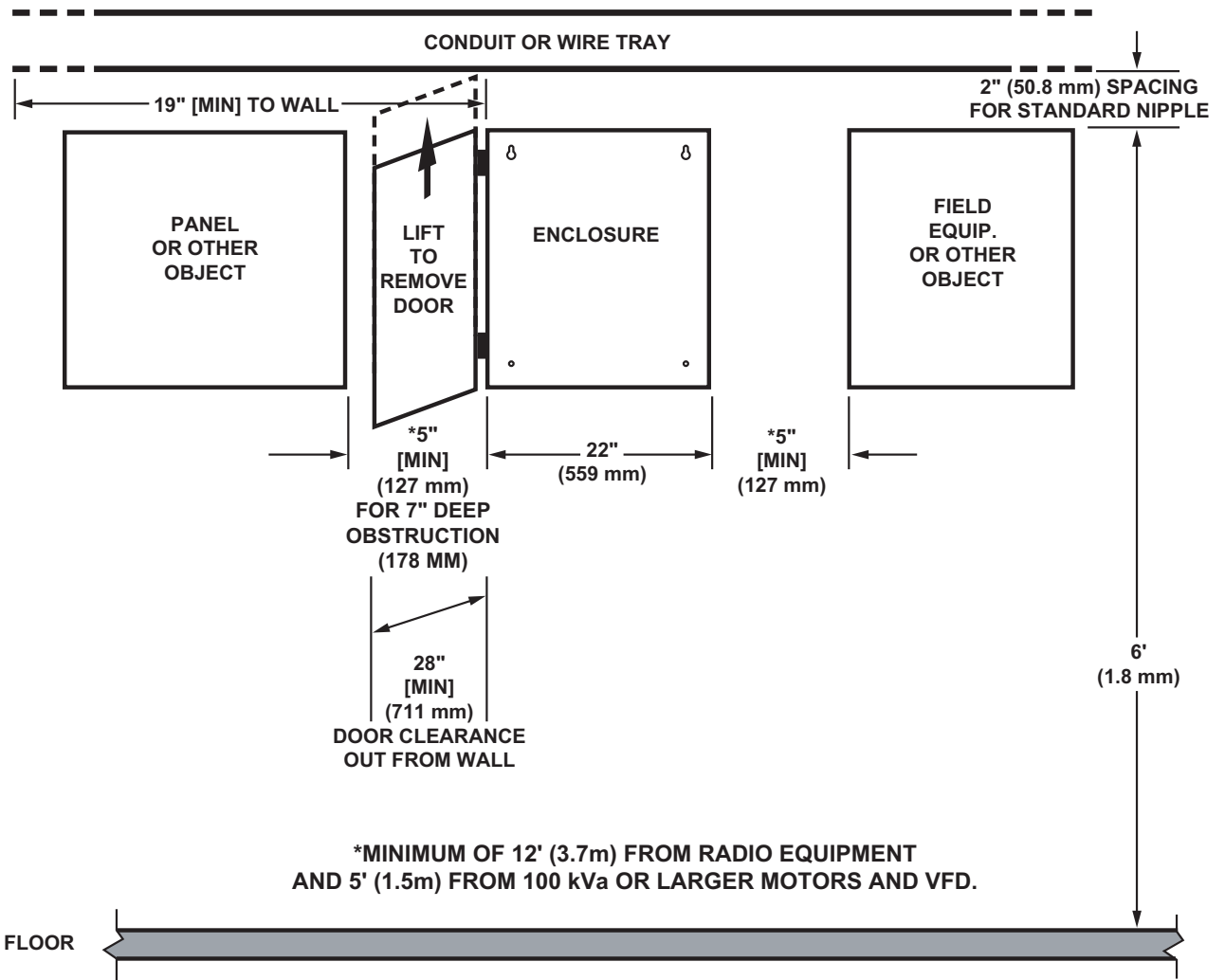

- Space between door panel and opening obstruction must be at least 11 inches (279.4 mm) to allow for door removal at 40 degrees, or 28 inches (711 mm) with a cabinet mounting at least 19 inches (483 mm) from the left side wall to allow door to completely open at 135 degrees.
- 5 inches (127 mm) minimum horizontal distance between the enclosure and any obstruction to the left and right.
- 7 inches (178 mm) minimum depth out from the wall on the left (hinged) side for door clearance.

Chapter 3—Applications

Chapter 3 describes the program and applications provided with or available for the PXC Modular Series. The following topics are discussed in this chapter:

- Operator Interface
 - Field Panel GO
- Powers Process Control Language (PPCL) Point Database and Control Program
 - Control Programs
 - Point Database
- Applications
- Customized Applications

Operator Interface

An operator issues commands or requests to the PXC Modular using an operator terminal and the operator interface. The operator interface is the software that allows the operator to communicate interactively with the PXC Modular Series. The operator interface does the following:

- Interprets and processes commands entered from operator terminals.
- Formats and sends all output directed to the operator.
- Provides levels of operator access that control an operator's authority to perform certain functions.

The operator interface is described in detail in the *APOGEE P2 ALN Field Panel User's Manual* (125-3019) or *APOGEE BACnet ALN Field Panel User's Manual* (125-3020). This manual is designed to help you become familiar with and use the operator interface. It describes the functions necessary for everyday operation of your system, plus the higher-level functions for commanding, displaying, editing, scheduling, networking, alarm management, and others.

Field Panel GO

The Field Panel GO license provides a Web-based user interface for your APOGEE® Building Automation System. It is an ideal solution for small or remote facilities with field panels on an Ethernet TCP/IP Automation Level Network (ALN).

A Field Panel GO Web Server-enabled controller can accommodate an unlimited number of user accounts, with up to two concurrent operator sessions. And each user account can be defined with customized levels of access and privileges to the system.

Field Panel GO encompasses the following operator applications:

- Alarm Status and acknowledgement
- Graphical Monitoring and Control
- Point Commander
- Schedule Overrides
- Status Reporting
- Historical Data Reporting
- Setup and Customization

Contact your local Siemens Industry representative for more information on Field Panel GO.

Field Panel Web Server

The Web Server resides on a TCP/IP-based BACnet PXC Compact 36 and/or PXC Modular controller. This means that the same field panel can serve as an automation controller, with full building automation and I/O features, and a host for the Web Server application. This eliminates the high cost of a separate “Web appliance” or dedicated Web server, which competitive solutions require be added to a building automation network.

The Web Server allows system-wide access through a single log-in. Web pages can be populated with data from any BACnet IP-enabled PXC controller and associated FLN devices. The Web Server will automatically connect and display data from BACnet PXC Modular or PXC Compact controllers that have the Web Services license enabled.

Any client device running Microsoft Internet Explorer 6.0 (IE6) or later, or Firefox 3.6 or later can be used to access the Field Panel Web Server. A Web Server-enabled controller can accommodate an unlimited number of user accounts. Each user account can be defined with customized levels of privileges and access to the system.

See the *Field Panel Web Server User Guide* (125-3584) for more detailed information.

The Field Panel Web Server encompasses the following operator applications:

- Graphical Monitoring and Control
- Network Layout
- System Status Bar
- Alarm Status and Acknowledgement
- Point Commanding
- Scheduling
- Graphical Trend Display
- Reporting
- Configuration and Customization
- Remote Notification

Graphics

- Customized system graphics
- Live animation of equipment
- Real-time point values and status updates

Network Layout

- View network layout
- Navigate to other Web-enabled panels
- Search database for individual points

System Status Bar

- Visual indication of new alarms and unacknowledged alarms
- Visual indication of out of service, faults, and failed devices

- Ability to view, filter, and acknowledge system alarms from a single page

Point Commanding

- Change point values
- Place points “Out of Service”
- Command BACnet MS/TP and P1 FLN points

Scheduler

- View schedules in a daily, weekly, or monthly view
- Add and delete schedules
- Create exceptions for existing schedules

Reporting

- Generate Point Log Report with multiple filters

Graphical Trend Display

- View one or more trends on a single display
- View raw data values and export to CSV file
- Print trend graph to network printers
- Display points with current values

Configuration and Customization

- Custom Welcome Page
- Translators user interface to any browser-supported language
- Customize font sizes and display colors

Powers Process Control Language (PPCL) Control Program and Point Database

The control programs and point database are stored in RAM. This information can also be saved or loaded into the PXC Modular using APOGEE Datamate software or Insight software.

Control Programs

The control programs define all user-defined control logic, calculations, applications, and so on for the PXC Modular. PPCL is written in an English-based programming language called Powers Process Control Language (PPCL). It is a powerful programming language developed specifically for controlling Heating, Ventilating, and Air Conditioning (HVAC) equipment. Multiple PPCL programs can be run simultaneously to provide instructions for the PXC Modular to operate equipment, control system loads, and optimize the system operation.

For a complete description of PPCL and how to use it, see the *APOGEE Powers Process Control Language (PPCL) User's Manual* (125-1896). This manual is available from your local Siemens Industry representative.

Point Database

The PXC Modular Series has the basic capabilities required to control and monitor a facility. However, the operator (or the installer) must program specific instructions into the PXC Modular and create databases that are customized for your particular facility. The databases contain information, such as point names, addresses, schedules, and alarm information for the equipment being supervised by the PXC Modular.

The PXC Modular uses information from the point database to define each point so that the firmware and the software know how to evaluate or command the point.

Among the items kept in the point database are the following:

- Location, or address of field inputs/outputs
- Logical point names and descriptions of points
- Point type
- Alarm information
- Current value of a point
- Information to convert analog signals to engineering units (slope and intercept constants)

The point database is described in detail in the *APOGEE P2 ALN Field Panel User's Manual* (125-3019) or *APOGEE BACnet ALN Field Panel User's Manual* or (125-3020).

Applications

Applications are an important part of the energy management capabilities of your system. The applications that you can incorporate into the operation of your system include:

- Adaptive Control
- Alarm Management
- Daylight Saving Time
- Equipment Scheduling
- Loop/Loop Tuning
- Start/Stop Time Optimization (SSTO)
- Time and Calendar (schedules, Daylight Saving Time)
- Trend Data Collection
- User Access and Privileges

Adaptive Control

Adaptive control is a closed loop control algorithm that auto-adjusts to compensate for mechanical system/load/seasonal changes. It is designed to eliminate the compromises of traditional Proportional, Integral, Derivative (PID) control. When compared to traditional PID control, adaptive control provides more efficient, robust, fast, and stable control. Adaptive control achieves superior performance in a dynamic, non-linear system in terms of response time and holding steady state, while minimizing error, oscillations, and actuator repositioning.

Alarm Management

An alarm is a status that indicates whether a point value or state is above or below a defined value. Alarm management is the strategy used to define, route, acknowledge, and resolve those alarms.

Points are defined as alarmable for the following reasons:

- **To prevent critical problems.** Points that affect human safety or can cause a severe problem in building operation should be defined as alarmable. For example, an alarm that notifies you that the temperature of a heating coil is too low and action must be taken before it freezes.
- **To notify you when equipment is not functioning properly.** Sometimes problems may occur and go unnoticed. Alarming is a useful tool to identify equipment that is not working properly and to prevent other devices from becoming damaged.
- **To announce scheduled maintenance.** For example, an alarm can notify you when it is time to change air filters.

Daylight Saving Time

The Daylight Saving Time (DST) functionality adjusts the system time to match the daylight saving time change-over. If your area uses daylight saving time, this feature offers a convenient method to automatically adjust the system clock.

Equipment Scheduling

Equipment Scheduling is designed to provide 365-day, time-based control of a space in a facility. The basic design of this application begins with a definition of the space, called a zone. The state of the zone dictates how the field panel controls the points associated to that space. The state of the zone is known as the mode (in this document it is referred to as the current mode value of the zone).

Loop/Loop Tuning

The loop application is the PPCL Proportional, Integral, Derivative (PID) control loop algorithm. The loop tuning application evaluates and calculates gains and sample times for existing LOOP statements in PPCL. This feature calculates appropriate Proportional, Integral and Derivative (PID) gains and sample time for a selected control loop, based on specific building and control information defined in the LOOP statement. When complete, you decide how to apply the newly calculated variables.

Start-Stop Time Optimization (SSTO)

Start/Stop Time Optimization (SSTO) is an optional, self-adjusting routine that affects the start and stop times of various occupancy modes. SSTO can help conserve energy by starting a heating or cooling process, prior to occupancy, as late as possible. SSTO can also stop heating or cooling a zone as early as possible, prior to vacancy.

For example, a meeting in August occurs at 1:00 P.M. and lasts until 4:00 P.M. Based on the information provided in SSTO parameters, the equipment scheduling application calculates the latest possible time cooling can start and still reach the cooling setpoint.

Also, calculations are made to determine the earliest time cooling can stop without affecting comfort limits.

Time and Calendar

Calendar dates (in the form of day shifts and replacement days) are entries used to supplement the Equipment Scheduling application.

Time functions compensate for Daylight Savings Time (DST) and provide time-based control for building equipment.

Trend Data Collection

Trending is a function that records point data over time. Trend data is either collected when the current point value changes by a specified amount (the trend COV limit), or point values are recorded after the system waits a specific amount of time and then the process is repeated.

Trend data can be uploaded from the field panel to the Insight workstation for storage and reporting, and the data can be converted to several spreadsheet formats for further analysis and reporting.

User Access and Privileges

A user issues commands or requests to the PXC Modular Series using an operator terminal and the operator interface program that resides in the PXC Modular Series. The operations that a particular user can perform depend on the access level assigned to each field panel function in their user account.

User accounts are used to manage access and security for field panels on a specified Automation Level Network (ALN). By creating individual accounts, a system administrator can control each user's access to objects and functions residing in field panels on a specified ALN.

Specifically, a system administrator can perform the following tasks:

- Define the users that can access an ALN
- Assign access to access groups
- Assign privileges to field panel functions residing on an ALN

Controlling User Access to Field Panel Functions

The following four access levels can be assigned to any field panel function for any user.

- **No Access** – Users cannot see the function.
- **Read Only** – Users can only view the value or status of objects.
- **Command** – Users can command or display the value or status of objects.
- **Edit** – Users can add, delete, command, modify, and view objects.

Example

If a user has a Command access level for the Point Editing function, then only the functionality required to command a point is available to them. They do not see or have access to the prompts required to add, modify, or delete a point definition.

For more information on user accounts and privileges, see the *APOGEE P2 ALN Field Panel User's Manual* (125-3019) or *APOGEE BACnet ALN Field Panel User's Manual* (125-3020).

Customized Applications

Some PXC Modular Series applications are created in the Powers Process Control Language (PPCL). These applications use PPCL statements and additional hardware to perform customized operations or functions in your system. Examples of applications created in PPCL include:

- Duty Cycling
- Enthalpy and Dry Bulb Economizer Control
- Peak Demand Limiting (PDL)

Information on how to customize these applications for your facility is included in the APOGEE Powers Process Control Language (PPCL) User's Manual (125-1896) and the *APOGEE P2 ALN Field Panel User's Manual* (125-3019) or *APOGEE BACnet ALN Field Panel User's Manual* (125-3020). These manuals are available from your Siemens Industry representative.

SNMP

The Simple Network Management Protocol (SNMP) Agent is a firmware feature that has been added to BACnet Firmware Revision 3.2.3 and later. The SNMP Agent allows points in the field panel to communicate with an SNMP manager over Ethernet.

SNMP is an application layer protocol that facilitates the exchange of management information between network devices. It is part of the Transmission Control Protocol/Internet Protocol (TCP/IP) suite. SNMP enables network administrators to manage network performance, find and solve network problems, and plan for network growth.

Three versions of SNMP exist: SNMP version 1 (SNMPv1), SNMP version 2 (SNMPv2), and SNMP version 3 (SNMPv3). All three versions have a number of features in common, but SNMPv2 offers enhancements such as additional protocol operations. SNMPv3 offers additional enhancements to Internet security and communities.



SNMP uses UDP ports 161 and 162, which must be opened within the firewall settings.



The panel may coldstart after the SNMP license is loaded.

For more information, see the *SNMP Agent Quick Start Guide* (140-0891).

3 Chapter 4—Troubleshooting

**NOTE:**

The following information is for qualified service personnel only.

Chapter 4 describes corrective measures you can take if you encounter a problem with a PXC Modular Series controller. If you encounter a symptom or a problem not covered in this manual, contact your Siemens Industry representative. The following topics are discussed in this chapter:

- Service Information
 - Electrostatic Discharge Requirements
 - Error Status Messages
 - Ordering Replacement Parts
 - Replacing the Batteries
 - Reinstalling the Mounting Tabs
- Troubleshooting the PXC Modular and TX-I/O Island Bus

3.1 Service Information

This section describes corrective measures you can take if you encounter a problem with a PXC Modular Series controller.

If you encounter a symptom or a problem not covered in this manual, contact your Siemens Industry representative.

**NOTE:**

When removing power to a controller to perform maintenance or service, make sure that the person in charge of the facility is aware of this and that appropriate steps are taken to keep the building in control.

**NOTE:**

When troubleshooting, record the problem and what actions were performed immediately before the problem occurred. Being able to describe the problem in detail is important should you need assistance from your local Siemens Industry representative.

To view the status of the PXC Modular and to call up reports for troubleshooting, you can use an operator's terminal and the operator interface or an Insight workstation. For more information, see the following documentation:

- *APOGEE P2 ALN Field Panel User's Manual* (125-3019) or *APOGEE BACnet ALN Field Panel User's Manual* (125-3020).
- *Insight Revision 3.x Documentation*. To view this documentation, see the Insight Online Documentation window, which you can access from the Insight Main Menu or the Insight program group.

It is good practice to back up the PXC Modular database routinely and whenever changes are made to the database or new equipment is added.

While performing the troubleshooting procedures outlined in this manual, you may wish to refer to the APOGEE Wiring Guidelines for Field Panels and Equipment Controllers (125-3002).

3.1.1 Electrostatic Discharge

An electrostatic discharge (ESD) wrist strap is generally not required when installing or servicing a PXC Modular. However, if the field panel is installed in a very dry environment where a high static discharge is likely, an ESD wrist strap is recommended.

3.1.2 Error Status Messages

For error status message descriptions, see the *APOGEE P2 ALN Field Panel User's Manual* (125-3019) or *APOGEE BACnet ALN Field Panel User's Manual* (125-3020).

3.1.3 Ordering Replacement Parts

If a PXC Modular Series is not operating correctly, it should be replaced.

3.1.4 Replacing the Batteries



⚠ CAUTION

AC power must be ON during battery replacement. Otherwise, data loss will occur.



NOTE:

The battery is taped in the tray to secure it during shipping. The tape does not need to be replaced.

1. Pull the release tab on the curved side of the battery compartment cover.
2. Remove the battery compartment cover.
3. Remove the failed battery, and place a fresh battery in the tray with the positive (+) and negative (-) ends properly aligned.
 - For the AA battery, make sure the positive (+) and negative (-) ends are properly aligned.
 - For the coin cell battery, make sure the positive (+) side is facing up.
4. Replace the battery compartment cover.



NOTE:

The LOW BATT LED remains ON if an alkaline battery is used in Compact models with extended temperature range operation.

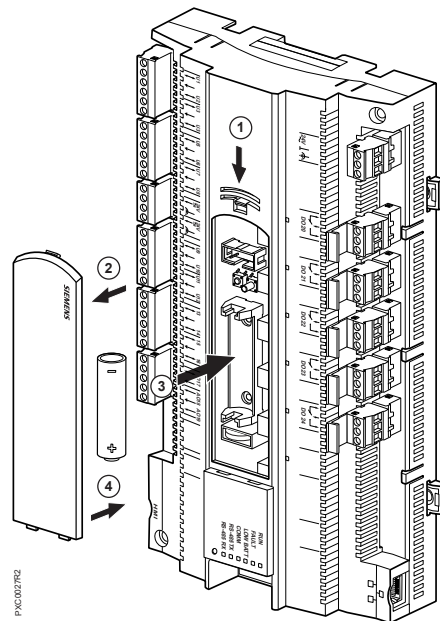

Figure 39: Replacing the AA Battery.

3.1.5 Reinstalling the Mounting Tabs

Do the following to reinstall a DIN mounting tab:

1. Place the wire spring clip into the pocket in the channel for the mounting tab.
2. Make sure the mounting tab is face down.
3. Working from the center (inside) of the base, slide the mounting tab into the channel. (See the following figure.)



NOTE:

The end with the screw hole slides into the channel first.

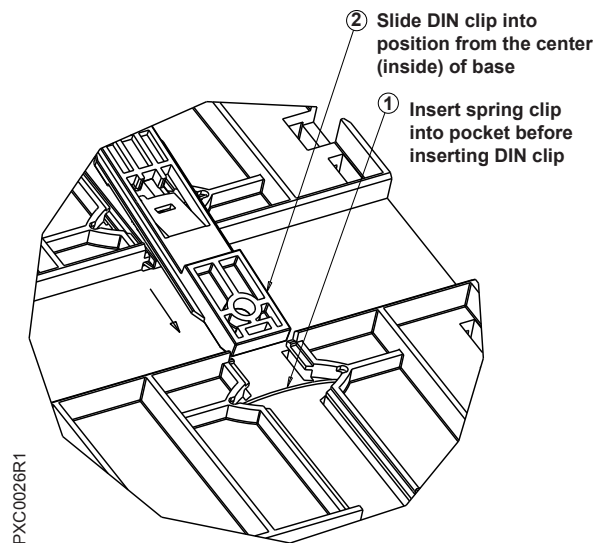

Figure 40: Reinstalling a DIN Mounting Tab.

3.2 Troubleshooting Modular Field Panels

Find the symptom below that best describes the problem and perform the corrective action that follows.

If the problem persists or other symptoms are present, contact your Siemens Industry representative.



⚠ CAUTION

Before performing any RS-485 Expansion Module troubleshooting procedures, complete a successful check-out of the PXC Modular.

3.2.1 BATT LOW LED

The BATT LOW LED is on or the battery low warning is displayed at the operator's terminal.



⚠ CAUTION

If you do not have a current backup, save the database before continuing.

1. Check that the mylar insert was removed from the AA (LR6) battery holder.
2. Check for polarity (+ to +) and (- to -).
3. Check that the battery is properly seated in the battery holder.
4. Replace the battery.

3.2.2 RUN LED

The RUN LED is on solid.

- The RUN LED is steadily lit during normal operation to indicate that 24 Vac power is ON and the application firmware has booted.

The RUN LED is off.

1. Verify that power is connected.
2. Check the service box and transformer ON switches.
3. If power is ON, verify that the application firmware has booted.
4. Measure voltage on 24V~ and \perp (Terminals 1 and 2).

The RS-485 Expansion Module RUN LED is off.

1. Check that the Expansion Module is properly seated on the DIN rail.
2. Verify the connection between the RS-485 Expansion Module and the PXC Modular.

3.2.3 TX and RX LEDs

3.2.4 Communication

Points cannot be read or commanded from the operator's terminal.

1. Verify that failed points have been properly addressed.
2. Verify the status of the points at the operator's terminal. Verify that points are not under Operator priority.

No communication over the FLN trunk.

1. Verify the FLN address and communication speed.
2. Verify the FLN trunk is connected to the correct FLN port.

3.2.5 Display



NOTE:

In USE FW REV TABLE ALN mode, RS-485 parameters are displayed and may be entered as a selection. However, when in RS-485 ALN mode, USE FW REV TABLE ALN parameters are not an available selection.

PXC Modular defaults to Ethernet ALN but continues to display parameters for RS-485 P2 ALN.

1. Generate the Field Panel Configuration report by entering the following at the HMI: **S, H, F, D** (System, Hardware, Fieldpanels, Display).
2. Verify the field panel settings on the Field Panel Configuration report (such as the ALN baud rate for P2 ALN or an IP address for Ethernet TCP/IP ALN).
3. Verify the current ALN type on the Field Panel Configuration report.

**NOTE:**

Changing the ALN type coldstarts the field panel.

4. If needed, change the ALN type by entering the following at the HMI: **S, H, F, C, E, M** (System, Hardware, Fieldpanels, Config, nEtype, Modify). (**S, H, F, C, S, T** for Firmware Revision 2.8.3 and earlier.)

3.2.6 Errors

PXC Modular program and database are not down-line loading properly.

- Verify that the Insight software is at least Revision 3.8.1 (P2) or 3.9.1 (BACnet).

Troubleshooting the TX-I/O Island Bus

The 24 Vac LED on the TX-I/O Power Supply or the P1 Bus Interface Module (BIM) is OFF.

1. Check for 24 Vac input.
2. Replace the fuse (4A, 5 × 20 mm, 250V, medium-acting, ceramic fuse).

All points on the TX-I/O island bus are failed.

- Verify all three signals, System Neutral (\perp), Communication Data (CD), and Communication Supply (CS) are connected throughout the entire TX-I/O island bus.

The I/O module status LED (under the address key) is flashing or the I/O point status LED is flashing on an open point. All points are operating normally.



⚠ CAUTION

The TX-I/O™ island bus must extend from the male bus connector of the TX-I/O Power Supply or Bus Connection Module.

- The TX-I/O Power Supply and Bus Connection Module only supply 24 Vac to I/O modules on the male bus connector.
- I/O modules on the female bus connector of the TX-I/O Power Supply or Bus Connection Module do not receive power and have a fault condition.

A point is failed or the point type displayed does not correspond to the point type defined in the database.

1. Using the job drawing or TX-I/O Island Bus layout sheet, verify that the address keys are in the correct module.
2. Reset the module to factory settings.
 - Verify that the module is supplied with 24 Vdc.
 - Remove keys that are in the wrong module.
 - Insert and then remove the reset key.
 - Cycle power to the module.
 - Insert the correct address key.

A current point on a Super Universal Module is failed.

- Verify that the sensor supply wire is connected to the DC terminal (3, 11, 20, or 28).

Glossary

The glossary contains terms and acronyms that are used in this manual.

1

100Base-TX: Fast Ethernet network implementation. 100Base-TX stands for 10Mbps baseband twisted-pair cable. The “X” stands for 100Base-X, the IEEE identifier for the media system used by 100Base-TX.

10Base-T: Ethernet network implementation. 10Base-T stands for 10Mbps baseband twisted-pair cable.

A

Adaptive Control: Closed loop control algorithm that auto-adjusts to compensate for mechanical system/load/seasonal changes.

AEM/AEM100/AEM200: Devices that allow APOGEE field panel networks to communicate with the Insight workstation across an Ethernet network. The APOGEE Ethernet Microserver (AEM) operates on a 10Base-T connection, but can also be routed across low speed networks (for example, across Frame Relay). The AEM100 supports auto-sensing 10Base-T and 100Base-TX Ethernet communication. The AEM200 adds a second serial port, allowing MMI access without disconnecting from the Insight network.

alarm priority: Ranking of a point alarm.

Automation Level Network (ALN) Devices: Extends Protocol 2 networks, leased line Modem, TI-2, Fiber Optic TIs, and TIE.

analog input-electric: Analog input point that receives either a current, voltage, or resistance input signal.

analog output-pneumatic: Analog output point that outputs a pneumatic signal.

AO-V point: Physical analog output point that generates a voltage signal.

Automation Level Network (ALN): The level in the communication hierarchy that consists of automation stations, automation devices, Application-Specific Controllers (ASCs), etc.

B

BACnet: A data communication protocol for Building Automation and Control Networks, ANSI/ASHRAE Standard 135-2004. BACnet allows devices from multiple manufacturers to work together on a network.

BACnet Broadcast Message Device (BBMD): BBMDs pass BACnet Broadcast Messages to other BBMDs on the network, allowing these messages to reach BACnet devices on the other side of a subnet router.

BACnet Encoded Name: A numeric representation of an object name that exceeds the APOGEE standard of 30 alphanumeric characters or less per name.

BACnet/IP: BACnet over IP protocol.

BBMD: See *BACnet Broadcast Message Device*.

broadcast: Destination IP address that represents all interfaces on all hosts. Usually, this is restricted to all hosts on the local subnet.

C

command priority: Ranking of a point command.

current value: Last commanded or sensed value of a logical point.

D

Device ID: Uniquely identifies a device object on the BACnet Inter network.

Device Instance Number: A number assigned to a BACnet device (for example, a BACnet field panel) that uniquely identifies it on the BACnet/IP network.

Device port: A USB Device port supports a generic serial interface for an HMI or Tool connection.

Device Specific Name: A textual representation of a BACnet object name that meets the APOGEE naming standard of 30 alphanumeric characters or less.

digitized value: Integer value used by the field panel to determine the logical value, state, and condition of logical points.

Domain Name Server (DNS): Common method of assigning computer names in UNIX-based networks. A DNS server maintains a list of host names and IP addresses, allowing computers that query them to find remote computers by specifying host names rather than IP addresses. DNS is a distributed database; therefore, DNS servers can be configured to use a sequence of name servers, based on the domain in the name being looked for.

Dynamic Host Configuration Protocol (DHCP): Protocol used for automatic TCP/IP configuration of nodes across a network. DHCP dynamically assigns addresses to nodes and allows for central administration of addresses.

dynamic point information: Information stored in the point database that may change during system operation and is not part of the data entered when defining points.

E

enclosure: Metal case that houses the field panel components.

English units: The foot-pound-second system of units for weights and measurements.

enhanced alarming: Application that allows floating alarms and alarm segregation.

Ethernet ready: Any device that communicates over Ethernet cabling. For example, both Ethernet ALN and BACnet/IP field panels are Ethernet ready, even though they use different communication protocols.

F

Field Level Network (FLN): A data communications link that passes information between an FLN device and an Automation Level Network (ALN) device. Terminal Equipment Controllers (TEC) are examples of FLN devices.

H

HAND-OFF-AUTO (HOA) switches: Manually operated control switches located on the face of HOA-equipped controllers that enable digital output points to be manually placed into HAND (ON), OFF, or AUTO control. Analog outputs can be placed into AUTO or multiple manual control positions.

Host port: A USB Host port provides support for USB modems and line printers.

Human-Machine Interface (HMI) port: Interfaces of various hardware and/or software units allowing the operator to transfer information to a technical system and/or receive information from the same.

I

Instance ID: The identifying number for objects (for example, points) within a BACnet device. Instance IDs can be assigned manually or automatically within the range set for the host device.

Internet Protocol (IP): A connection-less protocol that allows a packet to travel across multiple networks on its way to its destination. IP is the network layer of TCP/IP suite.

Intrinsic Alarming: BACnet alarming that incorporates alarm destinations (via Notification Classes) within a single alarm message.

M

multicast: Destination IP address that represents one or more interfaces. IP datagrams sent to a multicast address will be sent to all hosts participating in this multicast group.

N

notification class: Notification Class supports enable/disable based on the day of week and time of day and the alarm priority for all points associated with it.

P

Plain Old Telephone Service (POTS): Acronym for the standard telephone service that is used in most homes. Communication speed is generally restricted to 52K bps.

point condition: State of a point such as normal, alarm, alarm-by-command, failed, operator disabled, or proofing.

R

Read Only Memory (ROM): Non-volatile, permanent, but field-programmable memory that stores the operating system of the field panel. ROM stays intact even in the event of a power surge, a power loss, or failure of the battery backup.

Remote Automation Level Network (ALN): Automation Level Network (ALN) hosted by a remote field panel. The ALN is only seen at the remote site and at a centrally located Insight workstation.

remote field panel: Field panel not directly connected to the Insight ALN. Remote field panels connect over the telephone lines using a dial-up modem, or over an Ethernet network using an AEM/AEM100/AEM200.

S

service box: Component that receives the line power and converts it to 24 Vac for the field panel.

T

telnet: Program that runs on top of TCP/IP, it is the Internet standard protocol for remote login.

text-based terminal: Operator terminal that displays and accepts text only.

To-Fault: A BACnet event indicating that the BACnet object (point) has transitioned to the Fault state from some other state for the recipient or device. A BACnet object mayor may not require acknowledgement of this event by a user.

To-Normal: A BACnet event indicating that the BACnet object (point) has transitioned to the Normal state from some other state for the recipient or device. A BACnet object mayor may not require acknowledgement of this event by a user.

To-OffNormal: A BACnet event indicating that the BACnet object (point) has transitioned to the OffNormal state from some other state for the recipient or device. OffNormal states in BACnet are: OffNormal, high-limit, low-limit, and life-safety-alarm. A BACnet object may or may not require acknowledgement of this event by a user.

tombstone: Remnant or memento of a deleted record that is retained for a finite amount of time in a node's replication database. Tombstones are used to keep track of locally deleted records that must be deleted from replication partners during future global data replication sessions.

totalized value: Sum of information (in hours or minutes) about logical points such as run time, total volume, and degree days.

Transmission Control Protocol/Internet Protocol (TCP/IP): Protocol suite developed by the U.S. Department of Defense to link dissimilar computers across different kinds of networks. TCP/IP is the transport protocol employed by the Internet and is commonly used on Ethernet networks.

U

unbundle: Describes the action of entering a point that resides in an equipment controller's database into the field panel's database so that it can be monitored and controlled from the field panel.

Unicast: Destination IP address that represents a single interface to a single system. IP datagrams sent to a unicast address are sent to a single interface on a single IP host.

User Datagram Protocol (UDP): TCP/IP protocol that provides simple datagram services. UDP is a connection-less mode protocol that is layered on top of IP. UDP does not guarantee delivery and is not used for applications that require acknowledgements or re-transmission.

V

Virtual AEM: Without additional hardware, the Virtual AEM connects an RS-485 APOGEE Automation Level Network or individual field panels to a P2 Ethernet network. (Additional license required.)

Index

Numerics

10B/100B Ethernet port, 32

A

Adaptive Control, 75

alarm management, 76

APOGEE automation networking

Ethernet TCP/IP ALN, 20

Field Level Network (FLN), 25

P2 Ethernet and BACnet/IP ALN over an IP network, 23

remote ALN, 23

RS-485 P2 ALN, 19

Virtual AEM, 23

APOGEE automation networking:Automation Level Network (ALN), 18

APOGEE Ethernet Microserver (AEM), 14

applications

Adaptive Control, 75

alarm management, 76

calendar dates, 77

customized applications, 78

Daylight Saving Time (DST), 76

Equipment Scheduling, 76

loop/loop tuning, 76

Start-Stop Time Optimization (SSTO), 76

time functions, 77

trend data collection, 77

user access and privileges, 77

Automation Level Network (ALN), 18

10B/100B Ethernet port, 32

BACnet MS/TP ALN, 24

BACnet/IP, 23

HMI and Tool ports, 31

simultaneous ALN access, 18

Auto-Restore of database, 29

B

backup batteries

replacing, 80

BACnet

product features order of implementation, 13

BACnet MS/TP ALN

number of field panels supported, 24

BACnet protocol, 13

BACnet/IP ALN

number of field panels supported, 23

bus connection module, 62

C

calendar dates, 77

communication ports

10B/100B Ethernet, 32

HMI and Tool, 31

compatibility

BACnet product features order of implementation, 13

BACnet protocol, 13

sharing APOGEE P2 values with BACnet devices, 13

TCP/IP protocol, 14

customized applications, 78

D

Database Backup to Flash, 29

Daylight Saving Time (DST), 76

DHCP server, 14, 14

DNS node name format, 15

Domain Name Server, 14

E

electrostatic discharge (ESD), 80

Equipment Scheduling, 76

Ethernet TCP/IP ALN

number of field panels supported, 20

F

Field Level Network (FLN), 25

Flash Read-Only Memory (Flash ROM), 28

H

Human-Machine Interface (HMI)/Tool port, 31

I

IP addresses, 14

assignment, 14

island bus expansion (IBE) module, 62

L

loop/loop tuning, 76

M

Management Level Network (MLN), 18

memory

compressed ROM, 29

Flash Read-Only Memory (ROM), 28

Random Access Memory (RAM), 30

O

operator interface, 72

P

P1 bus interface module (BIM), 62

power supply module, 62

Powers Process Control Language (PPCL), 74

R

Random Access Memory (RAM), 30

remote ALN

number of field panels supported, 23

RS-485 P2 ALN

number of field panels supported, 19

S

service information, 79

electrostatic discharge (ESD), 80

reinstalling the mounting tabs, 81

replacing the batteries, 80

Start-Stop Time Optimization (SSTO), 76

T

TCP/IP protocol

address assignment, 14

compatibility, 14

default TCP/IP port number, 14

default UDP port number, 14

device registration, 14

DNS node name format, 15

network bandwidth, 15

network security, 15

required IP addresses, 14

Virtual AEM, 14

time functions, 77

trend data collection, 77

troubleshooting

24 Vac LED, 84

BATT LOW LED, 82

I/O module status LED, 84

RUN LED, 83, 83, 83

TX-I/O Product Range

power and bus modules, 62

TX-I/O island bus, 34

TX-I/O product range, 58

U

UDP port number, 14

USB Device port, 32

user access and privileges, 77

user accounts, 77

V

Virtual AEM, 23

default TCP/IP port number, 14

Issued by
Siemens Industry, Inc.
Building Technologies Division
1000 Deerfield Pkwy
Buffalo Grove IL 60089
Tel. +1 847-215-1000

© 2012 Copyright Siemens Industry, Inc.
Technical specifications and availability subject to change without notice.

Document ID 125-3582
Edition April 18, 2013